



Rizzetta & Company

Trevesta Community Development District

**Board of Supervisors' Meeting
June 2, 2026**

District Office:
2700 S. Falkenburg Road, Suite 2745
Riverview, FL 33578

www.trevestacdd.org

TREVESTA COMMUNITY DEVELOPMENT DISTRICT

Trevesta Clubhouse, 6210 Trevesta Place, Palmetto, Florida 34221

Board of Supervisors	David Hoyt William Dornetto Joseph Powlis Dean LaFolette Ted Piwowar	Chairman Vice Chair Secretary Assistant Secretary Assistant Secretary Assistant
District Manager	Matt O’Nolan	Rizzetta & Company, Inc.
District Counsel	Meredith Hammock Savannah Hancock	Klinski Van Wyk Klinski Van Wyk
District Engineer	Matt Morris	Morris Engineering

All cellular phones must be placed on mute while in the meeting room.

The Audience Comment portion of the agenda is where individuals may make comments on matters that concern the District. Individuals are limited to a total of three (3) minutes to make comments during this time.

Pursuant to provisions of the Americans with Disabilities Act, any person requiring special accommodations to participate in this meeting/hearing/workshop is asked to advise the District Office at least forty-eight (48) hours before the meeting/hearing/workshop by contacting the District Manager at (239) 936-0913. If you are hearing or speech impaired, please contact the Florida Relay Service by dialing 7-1-1, or 1-800-955-8771 (TTY) 1-800-955-8770 (Voice), who can aid you in contacting the District Office.

A person who decides to appeal any decision made at the meeting/hearing/workshop with respect to any matter considered at the meeting/hearing/workshop is advised that person will need a record of the proceedings and that accordingly, the person may need to ensure that a verbatim record of the proceedings is made including the testimony and evidence upon which the appeal is to be based.

TREVESTA COMMUNITY DEVELOPMENT DISTRICT

District Office · Riverview, Florida · (813) 533-2950

Mailing Address – 2700 S. Falkenburg Rd, Suite 2745, Riverview, Florida 33578

www.TrevestaCDD.org

**Board of Supervisors
Trevesta Community
Development District**

May 27, 2026

FINAL AGENDA

Dear Board Members:

The regular meeting of the Board of Supervisors of the Trevesta Community Development District will be held on **Wednesday, June 3, 2026, at 3:00 p.m.** at the Trevesta Clubhouse – **located at 6120 Trevesta Place, Palmetto, FL 34221**. The following is the final agenda for this meeting:

- 1. CALL TO ORDER / ROLL CALL**
- 2. PUBLIC COMMENTS**
 - A. Landscape Inspection Report and Responses Tab 1
 - 1. Consideration of Landscape Proposals Tab 2
 - B. Aquatics Report Tab 3
 - 1. Consideration of Aquatics Proposals..... Tab 4
- 3. STAFF REPORTS**
 - A. District Counsel
 - B. District Engineer
 - 1. Consideration of Lake Trevesta Pond 10 Erosion Proposals Tab 5
 - C. District Manager Report Tab 6
 - 1. Announcement of the Registered Voter Count Tab 7
- 4. BUSINESS ITEMS**
 - A. Discussion of Fiscal Year 2026-2027 Budget.....USC
 - B. Consideration of Resolution 2026-03, Approving the Fiscal Year 2026-2027 Budget and Setting a Public Hearing Tab 8
 - C. Consideration of Resolution 2026-04, Designating Officers Tab 9
 - D. Consideration of Arbitrage Engagement Letter Proposal Series 2016..... Tab 10
 - E. Consideration of Fast Signs Proposal Tab 11
 - F. Ratification of Midge Fly Proposal Tab 12
- 5. BUSINESS ADMINISTRATION**
 - A. Review of Financial Statements for March and April 2026 Tab 13
 - B. Consideration of the Operations and Maintenance Expenditures March and April 2026 Tab 14
 - C. Consideration of the Minutes for the Board of Supervisors Meeting held on April 8, 2026, Tab 15
- 6. SUPERVISOR REQUESTS AND COMMENTS**
- 7. ADJOURNMENT**

We look forward to seeing you at the meeting. In the meantime, if you have any questions, please do not hesitate to contact me at (813) 533-2950.

Sincerely,
Matt O’Nolan
Matt O’Nolan
District Manager

Tab 1

TREVESTA

COMMUNITY ASSET MANAGEMENT REPORT



April 17, 2026
Rizzetta & Company
Haley Pryor—Community Asset Manager



Rizzetta & Company
Professionals in Community Management

Summary/69th St. East/Trevesta Pl./Pond 20

General Updates, Recent & Upcoming Maintenance Events

- Water restrictions are in place until July 1, 2026. Turf installs and new plantings should be postponed or done in regard to limited days and times of irrigation availability.

The following are action items for the Bloomings Landscape to complete. Please refer to the item # in your contractor's response listing action already taken or anticipated time of completion. **Red Text** indicated deficient items from a previous report. **Bold Red Text** indicates deficient items for more than a month. **Green Text** indicates a proposal has been requested. **Blue text** indicates irrigation. **Underlined, bold, black text** indicates information or questions for the BOS. **Orange text** indicates STAFF items.

1. Trim and shape Wax Myrtles on the right side of the 69th St. monument. This area around Pond 20 is starting to look manicured and pruning the tops would make the community entrance even more polished. (Pic 1)



2. The palm trees and Oaks along the Trevesta Place entrance way need maintenance. The Oaks need suckers removed from the trunks and fruits need to be cut away from the palms.
3. The turf is struggling from 69th St E and along Trevesta Place on both sides. The median turf is also patchy with high weed pressure. Please inspect to rule out chinch bugs and advise on fertilizing and weed treatments. (Pics 3a&b>)



Trevesta Place

4. The Jasmine in the entrance median looks healthy and full. The Juniper needs some brown dead branches cut out. Please also inspect the gap in the middle where nothing is growing. We need to rule out pest damage or any type of fungal issue preventing root health. (Pic 4)



6. Documenting condition of turf along the North ROW of Trevesta place right before Aventa St. Please inspect for chinch bugs and other stressors besides lack of rain. (Pic 6)



5. The corners of Trevesta Place and Aventa St. has beds with Coontie Palms that need treatment. There is a white film on the fronds that suggest a mealy bug infestation. This is the starting location for this finding and there are other clusters of Coonties that also display the white residue. All plantings on Trevesta Place need to be inspected and treated. This includes both sides and the medians. (Pics 5a-c>)



Trevesta Place

7. Please make sure crews dispose of discarded irrigation hose pieces. Several old remnants were left behind around the lift station. (Pic 7)



10. Remove volunteer Holly sprout growing at the base of the Oak Tree on the South ROW of Trevesta Place towards Penesta Ln. (Pic 10)



8. In the median adjacent to the Trevesta Place lift station, we have a struggling Firebush with invasive weeds growing from the base. Please remove the dead branches and pull out the weeds competing for space. (Pic 8)



11. Weeds and grass is growing in expansion joints. Please treat flatwork to keep sidewalks and walkways free of weeds. The photo is at the lift station on Trevesta Pl. (Pic 11)



9. Inspect, diagnose, and treat the Coontie Palm cluster in the median headed towards Penesta Lane. The center of the cluster has a discolored zone that appears to deteriorate with the foliage wilting and unhealthy. (Pic 9>)



Trevesta Place/Levana St./Badini Way/Buffalo Rd.

12. Please remove the Oak sprout encroaching on the Sago Palm along the fence. This is on Levana St. and Trevesta Pl. (Pic 12)



15. Along Buffalo Rd., please hard prune the viburnum that are showing new growth at the bottom. There are two feet of dead at the top that makes it look like a dead bush. (Pic 15)



13. A lot of progress has been made to the pocket park on the South ROW of Trevesta Place. There is a dead Wax Myrtle and a palm with dead fronds that need to be removed at the far end of the park. (Pic 13)



16. Throughout the beds and behind the hedges, there are weeds that need to be pulled and cleared. They are sprawling aggressively along Buffalo Rd. at the wall. (Pic 16)



14. The CDD tract on Badini Way, that abuts a homeowner's property line, still has palms that need dead fronds and hanging fruit removed. The weeds in the bed also need removal as they are 3ft high now.

Buffalo Rd./Pond 8

17. Please have mowing crews remove weeds and discarded items around the ponds. Pond 8, between Buffalo Rd. and Tripoli, has a textile laying on the turf that needs removal during mowing events. (Pic 17)



18. Please have the Oak trees, that line the Buffalo Rd. wall, inspected for stability. Stake kits no longer needed should be removed. A concern is *girdling*, as the strap around the trunk becomes too tight for the growing tree with a thickening trunk. A few of the trees are already experiencing trunk damage and this could be fatal for the tree. (Pics 18a-c>)



Field Inspection

1. There is a broken spotlight behind the monument on 69th St. and Trevesta Place. (Pic 1>)



TREVESTA

COMMUNITY ASSET MANAGEMENT REPORT



May 15, 2026
Rizzetta & Company
Haley Pryor—Community Asset Manager



Rizzetta & Company
Professionals in Community Management

Summary/69th St. East/Trevesta Pl./Pond 20

General Updates, Recent & Upcoming Maintenance Events

- Water restrictions are in place until July 1, 2026. Turf installs and new plantings should be postponed or done in regard to limited days and times of irrigation availability.
- Fertilization application is scheduled for the month of May. This will be the last application until October, 2026.

The following are action items for the Bloomings Landscape to complete. Please refer to the item # in your contractor's response listing action already taken or anticipated time of completion. **Red Text** indicated deficient items from a previous report. **Bold Red Text** indicates deficient items for more than a month. **Green Text** indicates a proposal has been requested. **Blue text** indicates irrigation. **Underlined, bold, black text** indicates information or questions for the BOS. **Orange text** indicates STAFF items.

1. Continue the inspection of the Oak trees with stake kits throughout the community. Remove unnecessary kits and trunk straps. For kits still needed, ensure the trunk straps are not damaging the tree. Some straps may need to be adjusted to prevent girdling. The photo below is the line of trees along the wall that leads up to the monument on 69th St E. (Pics 1a&b)
2. At the left side of the monument, and Pond 20, the grass needs to be cut a little lower. Please line trim the tall weeds. Other than a few minor details, the monument landscape looks good. Trimming the Plumbago to remove the old growth and dead branches would make a big difference. (Pic 2)

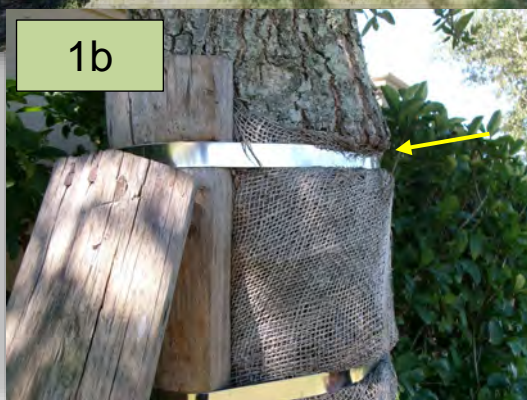

3. Please have crews remove and haul off the palm fronds that drop behind the monument. Bloomings has done a good job keeping up with debris in these hidden areas. This helps prevent time consuming pile ups and breeding grounds for mosquitoes and other pests. We have a couple of fronds needing removal. Also, please remove the suckers collecting around the trees surrounding the monument.



Trevesta Place

4. The turf along the entrance on Trevesta Place exhibits drought conditions. Some of the patchy and weedy turf was present before water restrictions were in place. The median turf shows drought stress. Please monitor after fertilization for improvement. (Pics 4a&b)



7. Please have crews remove trash and debris that collect on the median. This becomes a trap for windblown items and it starts to add up and become visible. (Pic 7)



5. In the front of the entrance median, the Juniper needs dead branches cut away. There is a center patch in decline. Please ensure this gets inspected and treated. Rule out pests or other stressors. (Pic 5>)

6. At the end of the median, the Jasmine needs some of the dead plant material removed. Once the dead branches are removed, the neighboring Jasmine can grow in laterally and fill out the bed. (Pic 6>)



Trevesta Place

8. Documenting construction work on Trevesta Pl. that effects the sidewalk and turf. This is the side that exits onto 69th St. (Pic 8)



11. Coontie Palms throughout the community are being treated with a fungicide and an insecticide to treat the sooty mold and scale. Please monitor regularly for improvement. (Pic 11)



9. Can we get an update on the leaning oak on Trevesta Pl. North ROW? This one is half uprooted. (Pic 9)



12. Plumbago past Levana St. has a section connected to a root system that is not producing. There is no bottom growth and appears to be declining. Please see proposal page to remove and replant with a 7 gallon replacement.

10. The Jasmine in the median across from Aventa St. is not thriving. Please remove the dead plant material. Once irrigation is reliable, we can replant something else. These placements were struggling before water restrictions. (Pic 10>)



Trevesta Place

13. The pocket nature park on Trevesta Pl. South ROW needs some tree maintenance. Remove dead fronds and fruits from the palms and Spanish Moss from Oaks. There are a few locations with dead plant material and some of the Wax Myrtles at the end need dead branches removed. This park will always need regular upkeep. It looks much better now but this will be ongoing in order to have a serene natural park that is safe to walk through. (Pics 13a&b)



14. In the middle of the pocket park, there is a significant amount of Thryallis that are struggling. Please do a hard prune on these placements to determine if the leftover roots will rejuvenate. (Pic 14>)

15. Most of the Ixora along the sidewalk in the park is thriving and blooming. Around the last Oak tree, the Ixora is struggling. This appears to be a different species of Ixora competing with the massive Oak tree for sustenance. The soil may be too alkaline here so please inspect and remove dead plant material. Replanting Ixora here is not a wise option. (Pic15)



16. The Ixora across from Hevana Ct. is flourishing and growing tall but it does have the typical fungus found on this species. The account manager will be treating with a fungicide. This bed will have a follow up inspection in June.



Trevesta Pl./Badini Way/Buffalo Rd.

17. The turf between the sidewalk and curb of the pocket park has heavy weed pressure. Weeds can thrive in drought conditions so please treat for weeds and monitor after fertilization. The turf could improve with some rain and fertilization boost. (Pic 17)



20. Debris was left or dumped along the Buffalo Rd. bed that joins the monument. Please have it collected and removed. (Pic 20)



18. The CDD maintained tract on Badini Way that abuts the homeowner property line has a heavy weed build up in the mulch. Palms look much better after maintenance but please have crews pull these weeds and follow with an herbicide. (Pic 18)



21. Several Viburnum that surround the Buffalo Rd. monument are no longer alive. Please remove the four dead plantings. (Pic 21)



19. Along the beds that line the wall on Buffalo Rd., there are some dead Viburnum placements. Please remove and discard all plantings that are no longer viable. (Pic 19>)



Buffalo Rd.

22. The Buffalo Rd. bed that leads to the monument is lined with Cedar Trees that need to be inspected. A few are in decline and one may be too far gone already. Please inspect or have an arborist visit to diagnose and treat the remaining trees. If no longer viable, please remove. (Pics 22a&b)



22a

23. Please have an arborist inspect the Medjool Palms that line the monument and pond. While a green spear leaf exists, their could still be other stressors that threaten the longevity of the palms. The one on the far end, closest to the expressway, is the most concerning. (Pic 23)



23



22b

Field Inspection

1. There are two broken spotlights behind the monument on 69th St. and Trevesta Place and another one at the monument on Buffalo Rd. (Pics 1a-c)

2. The median sign and caution reflectors appear to have been hit across from Aventa Street on Trevesta Pl. Collision marks are present and the sign is crooked and pushed back. (Pic 2)



Proposals

1. Remove declining Plumbago on Trevesta Pl. past Levana St. The root system is not producing and there is no new growth. The bush is in decline, and removal is recommended to prevent pests and fungal diseases clinging to dying out vegetation. Please provide proposal to remove and replace with a 7 gallon Plumbago. (Pic 1)



Tab 2



Trevesta CDD

Bloomings Landscape is proposing to provide the labor and materials for the work listed below. Please initial next to approved work.

_____ Straighten up to 24 applicable leaning Oak Trees and backfill any holes associated with the work - \$4,500.00

_____ Center prune and lift canopies on up to 95 Oak Trees located along the Blvd. outside and inside the gate. Remove and dispose of all debris - \$9,500.00

_____ Remove dead Cabbage Palm inside the gate along the blvd. Remove and dispose of all debris - \$150.00

_____ Removal of dead plant material property wide excluding the dead tree in the wetland area across from 5808 Trevesta Pl. - \$825.00

_____ Remove 2 x declining Wax Myrtle

Trevesta CDD wishes to be provided with the services (defined above) by Bloomings Landscape and agrees to the terms and conditions of this proposal.

Total - \$18,880.00

Trevesta CDD

Authorized Rep.

Bloomings Landscape

Authorized Rep.

Date _____

Date _____

Tab 3



MONTHLY REPORT

APRIL, 2026



TREVESTA CDD
6120 TREVESTA PL
PALMETTO, FL 34221
19 PONDS



SUMMARY:

Winter is over and Spring is upon us. As air temperatures rise so will the water. With the water drought and a rise in temperatures we will see a great influx in Algae blooms. Some ponds may go dry if we see this continue through the month. We will be aggressively monitoring as well as treating all blooms and unwanted growth as it shows its self.



Pond #3 Treated for Algae and Shoreline Vegetation.



Pond #4 Treated for Algae and Shoreline Vegetation.



Pond #5 Treated for Algae and Shoreline Vegetation.



Pond #6 Treated for Shoreline Vegetation.



Pond #7 Treated for Shoreline Vegetation.



Pond #8 Treated for Shoreline Vegetation.



Pond #9 Treated for Algae and Shoreline Vegetation.



Pond #10 Treated for Shoreline Vegetation.



Pond #11 Treated for Algae and Shoreline Vegetation.



Pond #14 Treated for Shoreline Vegetation.



Pond #15 Treated for Algae and Shoreline Vegetation.



Pond #16 Treated for Shoreline Vegetation.



Pond #17 Treated for Algae and Shoreline Vegetation.



Pond #18 Treated for Algae and Shoreline Vegetation.



Pond #20 Treated for Shoreline Vegetation.



MONTHLY REPORT

MAY, 2026



TREVESTA CDD
6120 TREVESTA PL
PALMETTO, FL 34221
19 PONDS



SUMMARY:

As we move into summer we're coming in very dry. Water levels are dropping and as ponds get more shallow, blooms will be more frequent. Lower water depth helps with algae and submerged growth. Dyes are being used throughout the community as needed to prevent or slow down growth. Dissolved oxygen levels decrease as water levels drop and temperatures go up. Our team will be carefully treating and monitoring your sites. Hopefully we get a little rain along the way as we move into summer.



Pond #3 Treated for Algae and Shoreline Vegetation.

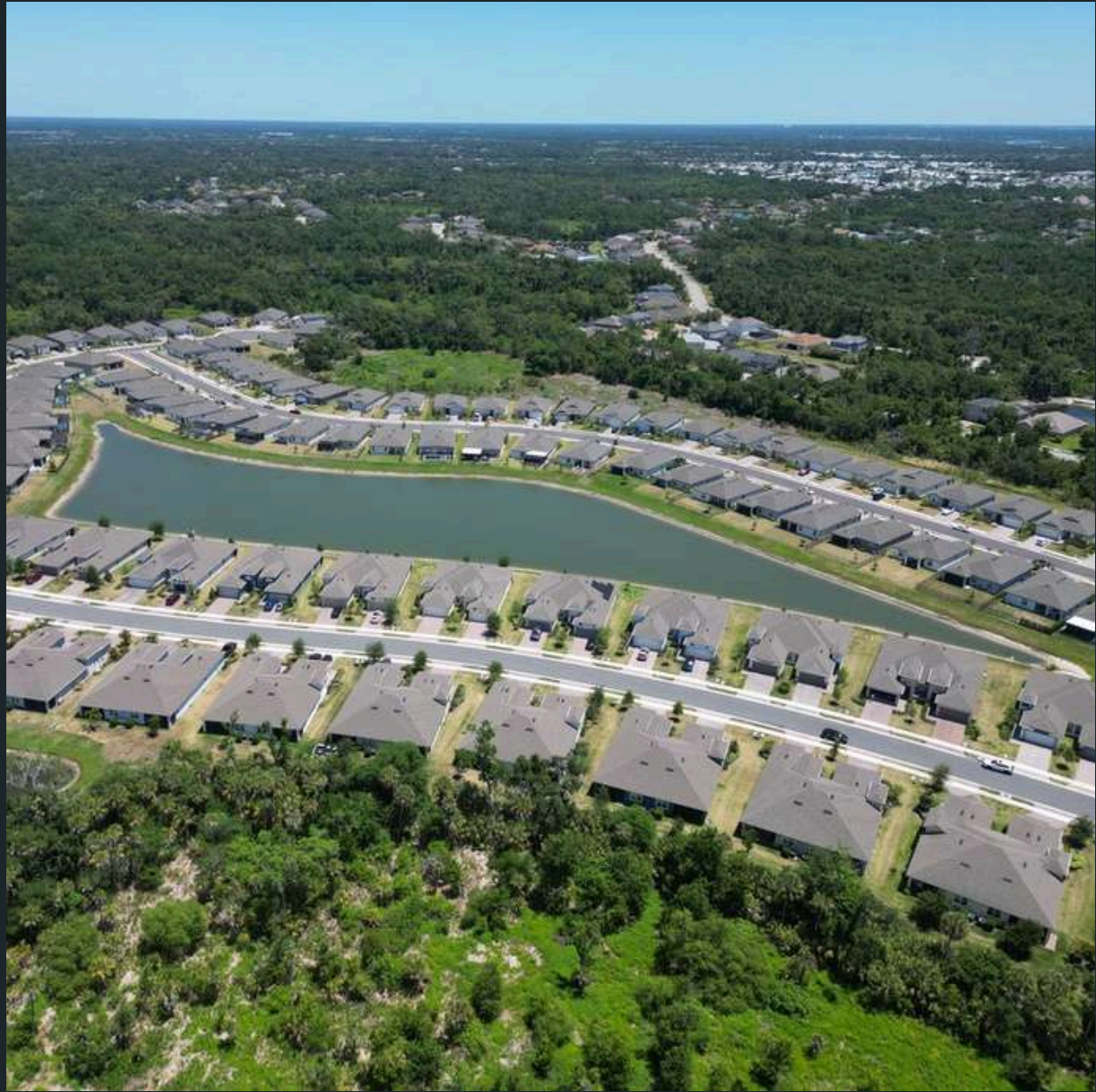

Pond #4 Treated for Algae and Shoreline Vegetation.



Pond #5 Treated for Algae and Shoreline Vegetation.



Pond #6 Treated for Shoreline Vegetation.



Pond #7 Treated for Shoreline Vegetation.



Pond #8 Treated for Shoreline Vegetation.



Pond #9 Treated for Algae and Shoreline Vegetation.



Pond #10 Treated for Shoreline Vegetation.



Pond #11 Treated for Algae and Shoreline Vegetation.



Pond #14 Treated for Shoreline Vegetation.



Pond #15 Treated for Algae and Shoreline Vegetation.



Pond #16 Treated for Shoreline Vegetation.



Pond #17 Treated for Shoreline Vegetation.



Pond #18 Treated for Algae and Shoreline Vegetation.



Pond #20 Treated for Shoreline Vegetation.

Tab 4



Mailing: PO Box 917 Parrish, FL 34219
 Physical: 11719 31st TER E Palmetto, FL 34221

813.564.2322
 www.sitexaquatics.com

Fountain/Aerator Agreement

This agreement is between Sitex Aquatics, LLC. Hereafter called "Sitex" and Trevesta CDD Located in Bradenton, Florida hereafter called "customer"

Customer: Trevesta CDD
 C/O: Rizzetta & Company
 Contact: Matt O'Nolan
 Address: 2700 S. Falkenburg Rd Suite 200 Tampa, Florida 33578
 Email: Monolan@rizzetta.com
 Phone: 813.533.2950

The Following bid is for an Airmax Aeration system to be installed at Pond #5 located in the Trevesta community.

Service	Cost
Airmax G60 Compressor w/5 diffusers & 2000' weighted tubing	\$8,949.00
Labor	Included
New Electric Service/Meter	TBD
Total cost	\$8,949.00

Scope: New Aeration system

Warranty- 3 year on parts & 1 yr on labor.

50% deposit due upon execution of agreement with remaining 50% due within 30 days of completion of installation. Overdue accounts may accrue a service charge. Credit card charges shall incur a fee of 3.5%.

Customer acknowledges that he/she has read and is familiar with the additional terms and conditions printed on the second page, which are incorporated in this agreement.

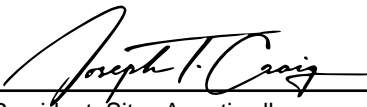
Accepted By _____ Date _____
 President, Sitex Aquatics llc.  Date 04/08/2026

Terms & Conditions

Payment

Sitex agrees to provide all labor, supervision, and equipment necessary to carry out the work. There shall be no variance from these specifications unless expressly stated through an addendum.

Responsibility

Customer is responsible for all electrical services to the control box, Sitex is not an electrical contractor nor claims to be responsible for any electrical responsibilities. Customer agrees to pay separate cost incurred by said electrical contractor.

Neither party shall be responsible for damage, penalties or otherwise for any failure or delay in performance of any of its obligations hereunder caused by strikes, riots, war, acts of Nature, accidents, governmental orders and regulations, curtailment or failure to obtain sufficient material, or other force majeure condition (whether or not of the same class or kind as those set forth above) beyond its reasonable control and which, by the exercise of due diligence, it is unable to overcome.

Sitex agrees to hold Customer harmless from any loss, damage or claims arising out of the sole negligence of Sitex. However, Sitex shall in no event be liable to Customer or other for indirect, special or consequential damage resulting from any cause whatsoever.

Scheduling

It is agreed by both Parties that the work performed under this Agreement will be done on a schedule that is sensitive to the overall function of the property. Additionally, it is understood that all work will be performed during the normal business week (Monday-Friday) unless otherwise stipulated.

Insurance

Sitex shall maintain the following insurance coverage and limits:

- (a) Workman's Compensation with statutory limits;
- (b) Automobile Liability;
- (c) Comprehensive General Liability including Property Damage, Completed Operations, and Product Liability.

A Certificate of insurance will be provided upon request. Customers requesting special or additional insurance coverage and/or language shall pay resulting additional premium to Sitex to provide such coverage.

This Agreement shall be governed by the laws of the state of Florida.



Mailing

Physical::

PO Box 917
Parrish, FL 34219

11719 31st Ter E
Palmetto, FL 34221

813.564.2322
www.sitexaquatics.com

Planting Agreement

This agreement is between Sitex Aquatics, LLC. Hereafter called "Sitex" and Trevesta CDD hereafter called "customer"

Customer: Trevesta CDD
C/O: Rizzetta
Contact: Matt O’Nolan
Address: 2700 S Faulkenburg Rd suite 2745 Riverview, FL 33578
Email: monolan@rizzetta.com
Phone: 813.793.8814

The Following bid is for the Planting of Pond #15 perimeter located in the Trevesta community in Ellenton, Florida.

Service	Cost
Pond #15-3 rows on 1' Center. Aprox 5020 Pickerel Weed bareroot plants	\$10,038.00
Installation	Included
Total cost	\$10,038.00

Scope: Area perimeter will be planted aprox 1-2' from high water mark, plants will be bare root & planted on 1' centers with 3 rows.

A deposit of 50% (\$5,019.00) is due upon execution of this agreement & for equipment to be ordered, with remaining 50% (\$5,019.00) due within 30 days of completion of installation. Overdue accounts may accrue a service charge.

Customer acknowledges that he/she has read and is familiar with the additional terms and conditions printed on the second page, which are incorporated in this agreement.

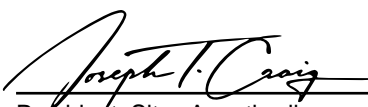
Accepted By	Date		05/06/2026
		President, Sitex Aquatics llc.	Date

Terms & Conditions

Sitex agrees to provide all labor, supervision, and equipment necessary to carry out the work. There shall be no variance from these specifications unless expressly stated through an addendum.

The Cost will be paid to Sitex in Two (2) equal payments, 1st payment is due before work is to begin & to secure scheduling final payment is due within 30 days of job completion. A surcharge of two percent (2%) per month will be added for delinquent payments. The Customer is responsible for any collection or attorney's fees required to collect on this agreement.

This Agreement will be for a _____ (n/a) month period. This Agreement shall be automatically renewed at the end of the _____(n/a) months. The monthly service amount may be adjusted, as agreed upon by both Parties, and set forth in writing to Customer. Both parties agree that service shall be continuous without interruption.

Additional Services requested by the customer such as trash clean up, physical cutting or paint removal, and other additional services performed will be billed separately at the current hourly equipment and labor rates.

Cancellation by either the Customer or Sitex may terminate the Agreement without cause at any time. Termination shall be by written notice, received by either the customer or Sitex at least thirty (30) days prior to the effective date of the termination.

Neither party shall be responsible for damage, penalties or otherwise for any failure or delay in performance of any of its obligations hereunder caused by strikes, riots, war, acts of Nature, accidents, governmental orders and regulations, curtailment or failure to obtain sufficient material, or other force majeure condition (whether or not of the same class or kind as those set forth above) beyond its reasonable control and which, by the exercise of due diligence, it is unable to overcome. • Sitex agrees to hold Customer harmless from any loss, damage or claims arising out of the sole negligence of Sitex. However, Sitex shall in no event be liable to Customer or other for indirect, special or consequential damage resulting from any cause whatsoever.

It is agreed by both Parties that the work performed under this Agreement will be done on a schedule that is sensitive to the overall function of the property. Additionally, it is understood that all work will be performed during the normal business week (Monday-Friday) unless otherwise stipulated.

Insurance

Sitex shall maintain the following insurance coverage and limits:

- (a) Workman's Compensation with statutory limits;
- (b) Automobile Liability;
- (c) Comprehensive General Liability including Property Damage, Completed Operations, and Product Liability.

A Certificate of insurance will be provided upon request. Customers requesting special or additional insurance coverage and/or language shall pay resulting additional premium to Sitex to provide such coverage.

This Agreement shall be governed by the laws of the state of Florida.

Pickerel Weed



Tab 5

To: Trevesta CDD From: Frank Nolte
Clearwater
Project/File: Pond 10 Erosion Review Date: April 22, 2026

Reference: Trevesta Stormwater Outfall Review

Stantec visited Trevesta on 3/25/26 to review reported erosion along the southern bank of Pond 10. Erosion is believed to have occurred over time due to wind driven wave action against exposed pond banks.

There are varying levels of erosion throughout this area, summarized in the location map below. Staff recommends immediate attention (1 year or less) to the Critical area due to the impacts to mower access and property damage if left in its current state. Staff recommends the Serious area be addressed within 1-2 years due to notable changes in the intended pond bank slope. Staff recommends the Fair area be addressed within 2-3 years due to the presence of minor erosion and slight changes in intended pond bank slope. The Good categorized areas are recommended to be addressed during the 2-3 year timeframe as well to provide continuous protection along the project limits.

Refer to photos below for current conditions of each area with typical recommended repair section.

Location Map



Reference: Trevesta Pond 10 Erosion Review

Critical Area:



Reference: Trevesta Pond 10 Erosion Review

Serious Area:



Serious Area (cont.)



Serious Area (cont.)



Reference: Trevesta Pond 10 Erosion Review

Fair Area:



Fair Area (cont.)



Reference: Trevesta Pond 10 Erosion Review

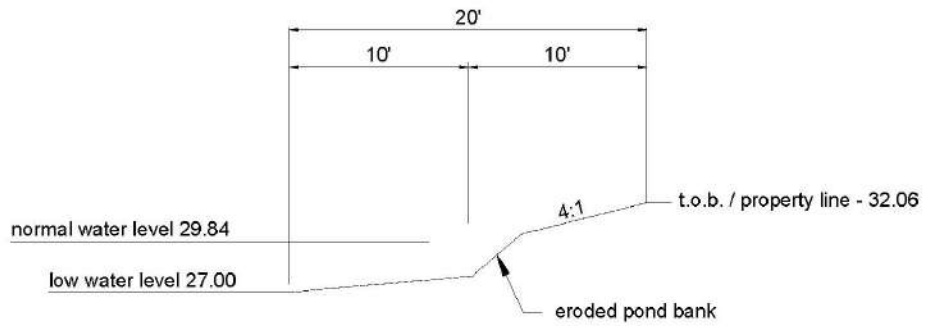

EXISTING POND BANK

N.T.S.

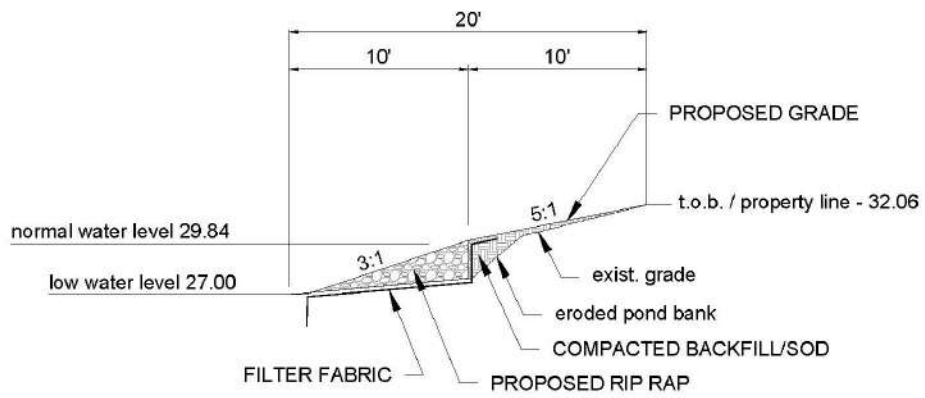

PROPOSED POND BANK

N.T.S.

Best regards,

STANTEC CONSULTING SERVICES INC.

FRANK NOLTE

Project Manager
Phone: (727) 431-1645
Frank.Nolte@stantec.com

Pond 10 Erosion Repair Staging and Access

Write a description for your map.

Legend

-  Access Easement
-  Material Staging Area

Replace broken concrete, sod and irrigation as needed. Match existing

Replace sod outside project limits as needed. Match existing

Project Limits

Replace broken concrete, sod and irrigation as needed. Match existing

Google Earth

Image Landsat / Copernicus
Data SIO, NOAA, U.S. Navy, NGA, GEBCO

700 ft



Based on the record information shown hereon, certified by a Florida licensed surveyor and mapper, I hereby certify that this project's improvements have been constructed in substantial conformance with the approved plans.

Matthew J. Morris, P.E.
Florida License # 68434

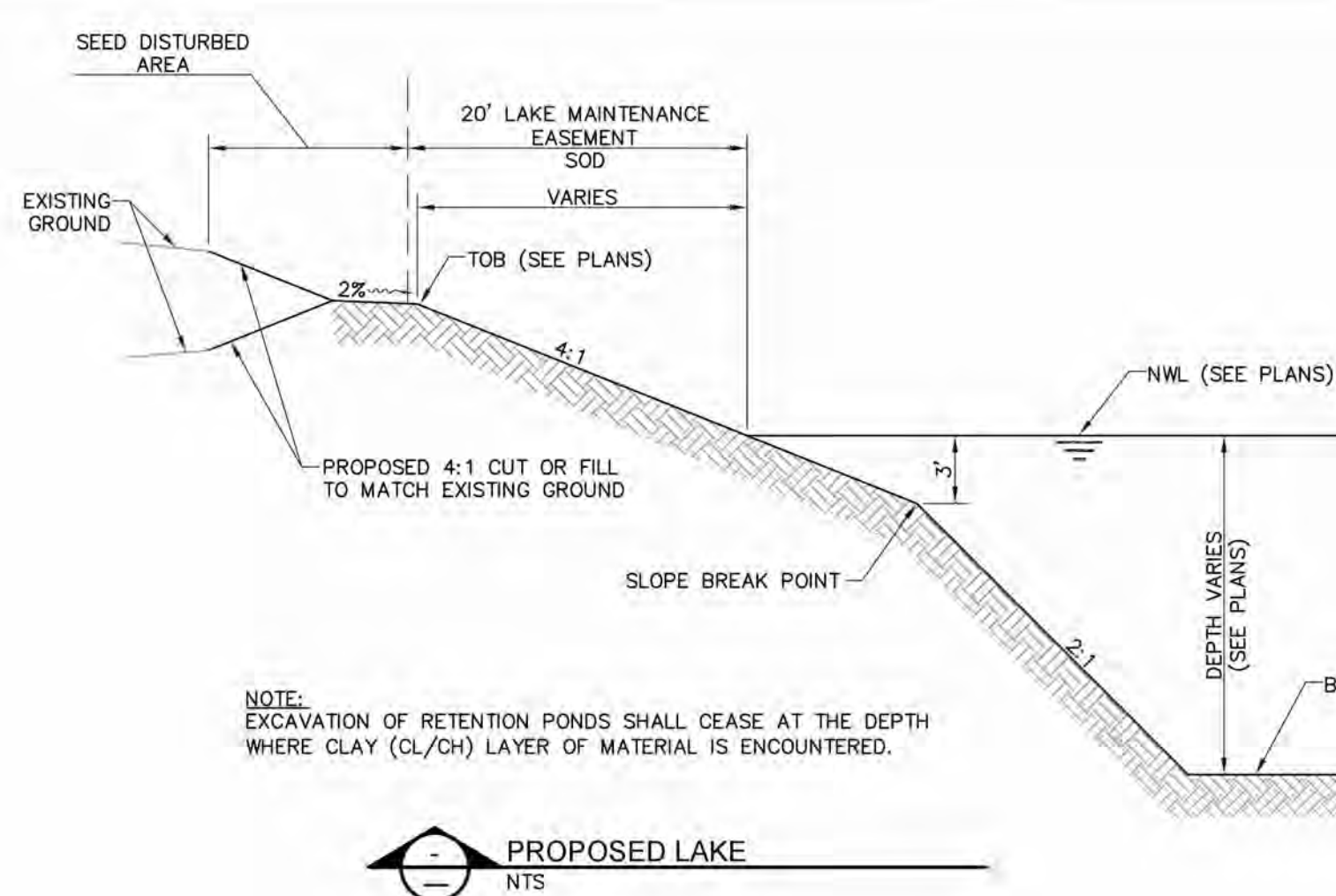
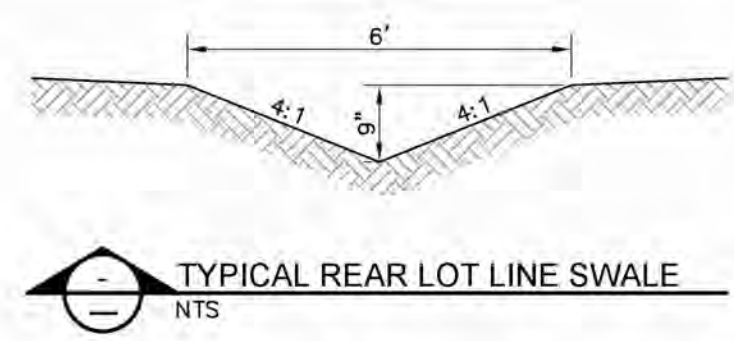

- NOTES:
1. CONCRETE SHALL BE 3000 PSI @ 28 DAYS
 2. CHAMFER ALL EXPOSED EDGES 3/4"
 3. RIP-RAP SHALL BE SUPPLIED AND CONSTRUCTED AS DEFINED IN THE F.D.O.T. SPECIFICATIONS SEC. 530, RIP-RAP, SPECIFICALLY SEC. 530-3.3 RUBBLE, 50 LB. MIN. NO BROKEN CONCRETE SHALL BE USED.
 4. FILTER FABRIC SHALL BE SUPPLIED AND CONSTRUCTED AS DEFINED IN THE F.D.O.T. SPECIFICATIONS SEC 514, PLASTIC FILTER FABRIC, SPECIFICALLY SEC. 514-3.4 RIP-RAP, INCLUDED IN UNIT COST OF ENDWALL.
 5. ENDWALL TO BE CONSTRUCTED PER FDOT INDEX 260 STANDARDS.

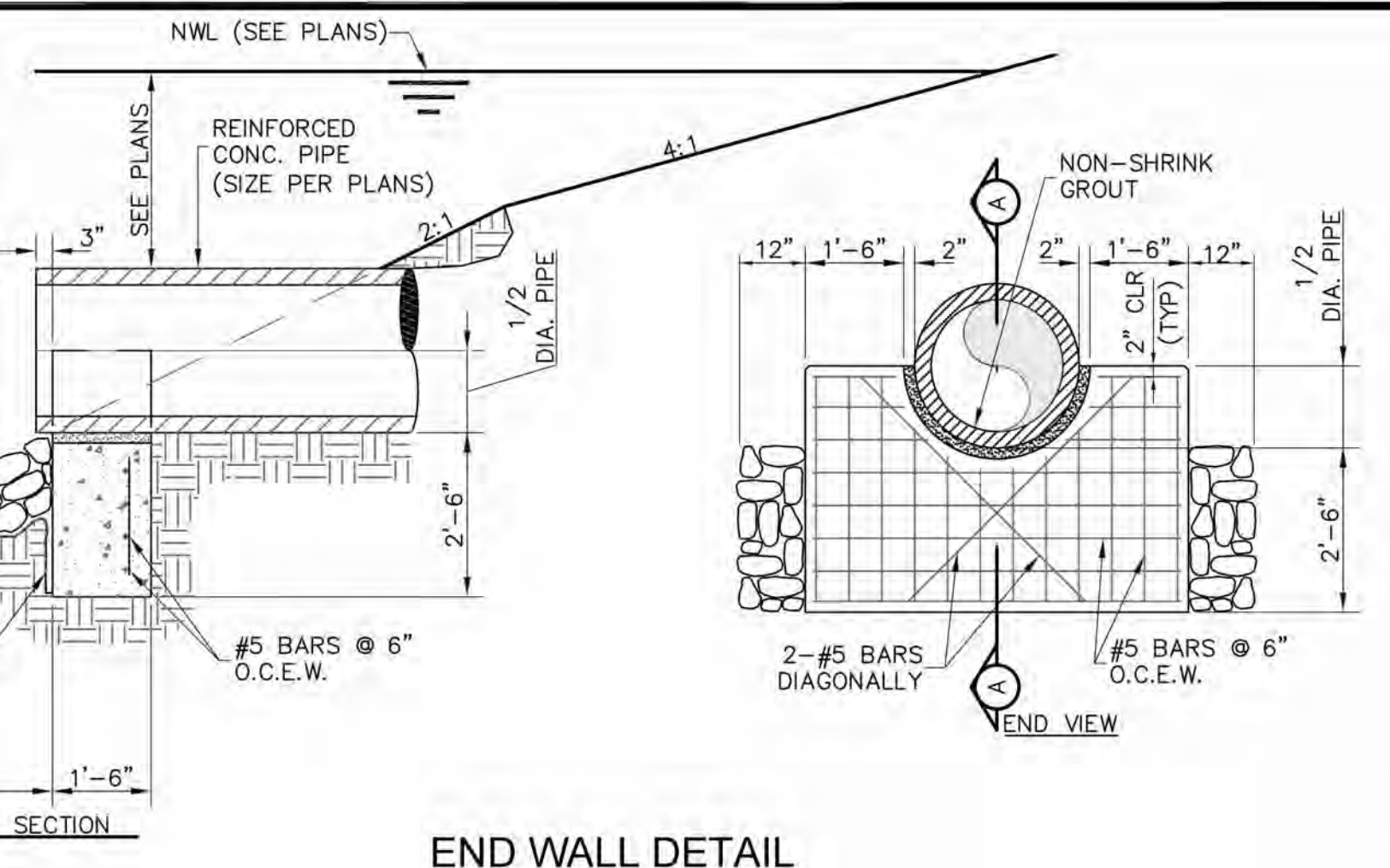

END WALL DETAIL

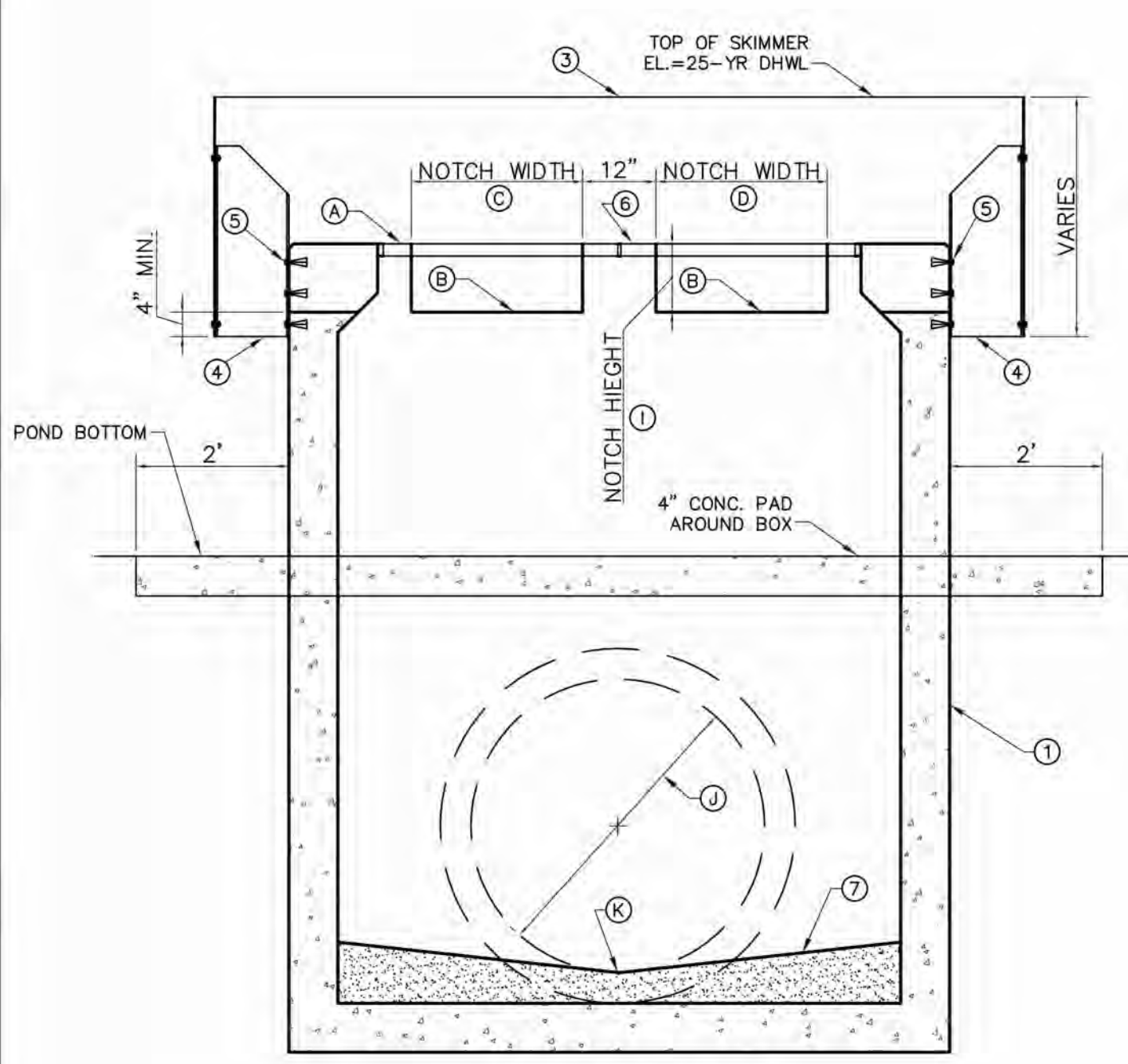

SECTION A-A
N.T.S.

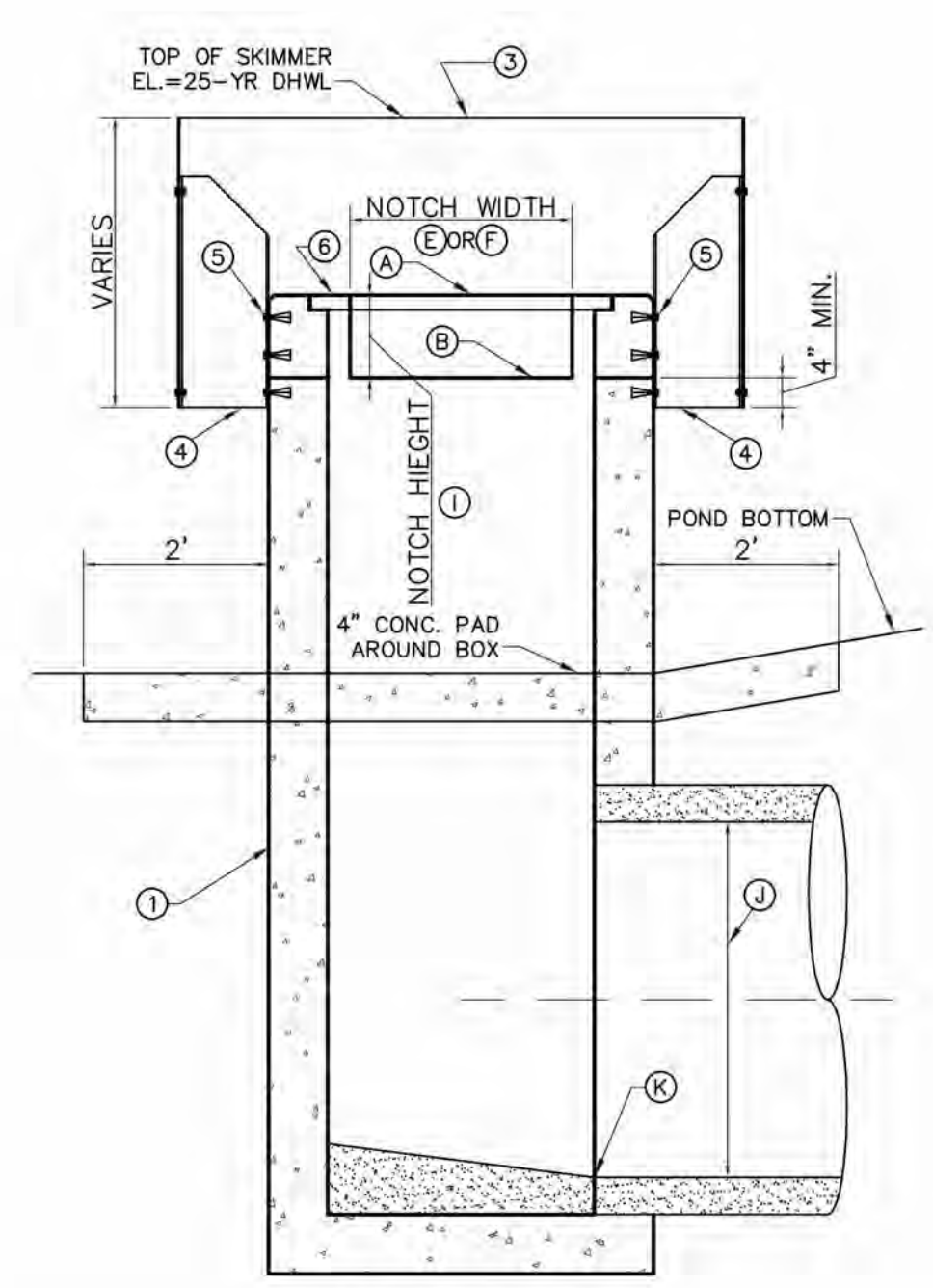

SECTION B-B
N.T.S.

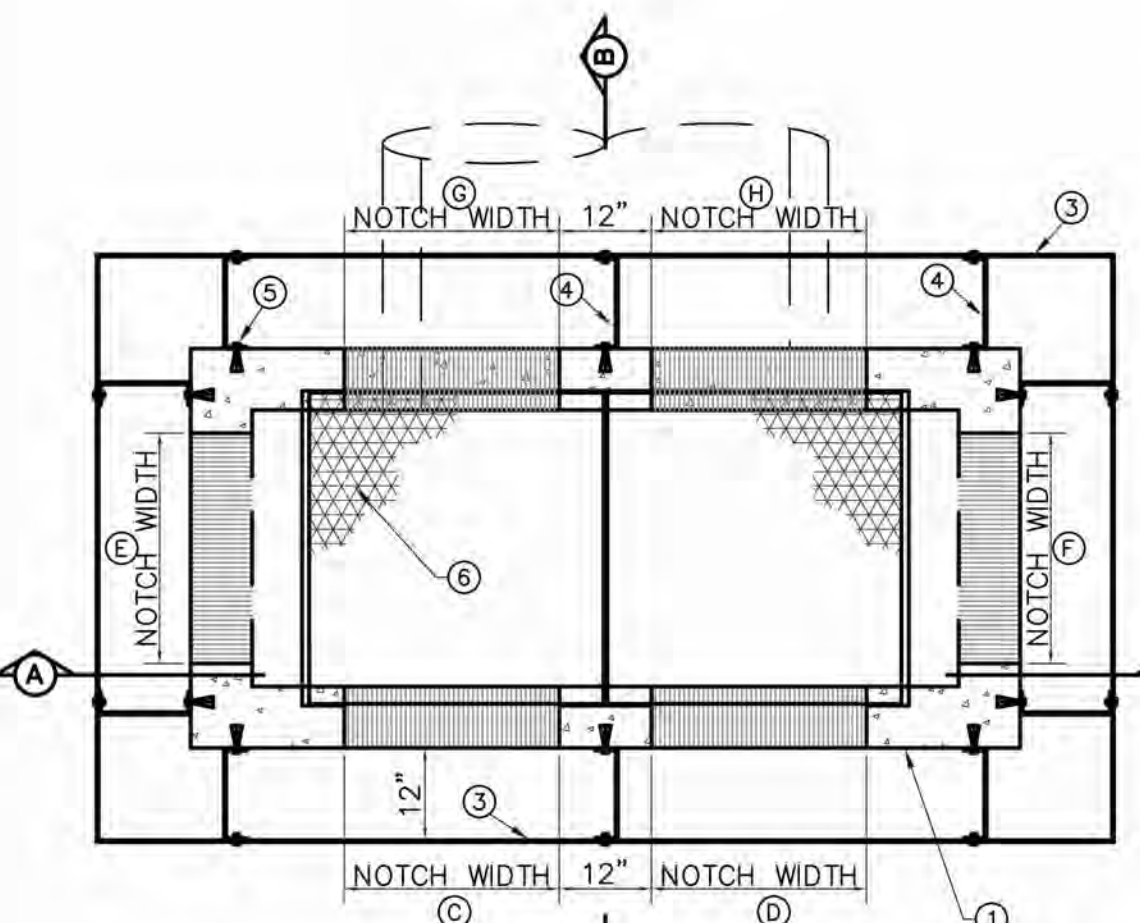

PLAN VIEW
N.T.S.

- CONTROL STRUCTURE NOTES:**
1. ALL CONTROL STRUCTURES TO BE MANUFACTURED IN ACCORDANCE WITH FDOT INDEX 232 AND SUPPLEMENTAL INDEX 201.
 2. SEE CONTROL STRUCTURE DATA TABLE FOR SPECIFICATION, ELEVATIONS AND DIMENSIONS FOR EACH STRUCTURE. SEE DRAINAGE PLAN TO VERIFY PIPE SIZE AND ALIGNMENT FOR EACH STRUCTURE.
 3. UNLESS OTHERWISE SPECIFIED, INSTALL 3/16" GLASSIMER" HSS-HIGH STRENGTH COMPOSITE SHEET SKIMMER PLATE WITH OPEN TOP AND BOTTOM. SKIMMER TO EXTEND AT LEAST 4" BELOW NOTCH INVERT, OR 4" BELOW GRATE ELEVATION WHEN NOTCH IS NOT PROVIDED.
 4. SKIMMER PLATE SUPPORT BRACKETS SHALL BE STEEL CHANNEL SECTIONS MC-12x10.6, CUT TO LENGTH AS REQUIRED FOR APPROPRIATE SKIMMER INSTALLATION, WITH 1 SHOP COAT AND 1 FIELD COAT OF KEMANA EPOXY B-6944 OR APPROVED EQUAL. ALL FASTENING HARDWARE TO BE STAINLESS STEEL.
 5. 3/8" DIAMETER STAINLESS STEEL EXPANSION ANCHORS, 3" LONG MINIMUM WITH STAINLESS STEEL WASHERS AND NUTS. SPACE BOLTS ONE FOR EACH 6" C.C. MAXIMUM SPACING AT EACH SUPPORT BRACKET.
 6. STEEL GRATE W/ EYEBOLT AND CHAIN, AS SPECIFIED PER FDOT INDEX 232
 7. FIELD POURED CONCRETE INVERT AFTER INLET AND PIPE ARE PLACED IN GROUND, 3000 PSI CONCRETE @ 28 DAYS. SLOPE 2" PER FT. TO DRAIN.
 8. BENCH MARK REQUIRED TO BE SET AFTER CONSTRUCTION IS COMPLETE. BENCH ELEVATION TO BE NOTED ON RECORD DRAWINGS.
 9. STAKEOUT POINT TO BE CENTER OF STRUCTURE. FIELD LOCATION MAY BE ADJUSTED TO FIT WITHIN LAKE BANKS OR FILL SLOPE MAY BE NECESSARY. ADJUSTED LOCATIONS TO BE APPROVED BY THE ENGINEER OR DESIGNATED REPRESENTATIVE.
 10. IF WETLAND RIM DITCH EXISTS, THEN THE LOCATION OF OUTFALL STRUCTURE ENTERING WETLAND SHALL BE LOCATED IN THE RIM DITCH. GRADING OF INSIDE BANK OF RIM DITCH TO ADJACENT WETLAND SEASONAL HIGH WATER LEVEL MAY BE REQUIRED TO PROVIDE POSITIVE DRAINAGE TO WETLAND.
 11. FDOT TYPE H STRUCTURE SHOWN, FOR STRUCTURE TYPES C, D, AND E, OMIT NOTCH OPENINGS "D" & "H" AND 12" WIDE DOUBLE GRATE SEAT SUPPORT RISERS AS SHOWN. THE CENTER SKIMMER SUPPORT BRACKETS AS INDICATED WITHIN THE 12" WIDE GRATE SEAT RISER SEGMENT SHALL ALSO BE DELETED FOR STRUCTURES OTHER THAN TYPE H.

CONTROL STRUCTURE DETAIL

CONTROL STRUCTURE DATA TABLE

STRUCTURE NO.	FDOT TYPE C,D,E OR H	NWL/SHWL IN FEET	A	B	C	I	J
			TOP GRATE ELEVATION (NAVD8)	NOTCH ELEVATION (NAVD8)	NOTCH WIDTH (IN)	NOTCH HEIGHT (IN)	OUTFALL PIPE DIA. (IN)
10-01	C	29.94	31.11 32.18	29.84 30.04	12.0	2.8 7.07	18
11-01	D	33.00	34.17	33.00	12.0	6.0	30
13-01	D	29.84	30.91 31.07	29.84 29.92	9.0	4.8 5.0	30
14-01	D	28.40	29.77 29.69	28.40 28.41	10.8 10.07	8.4 9.09	36
15-01	C	30.00	30.97 31.20	30.00 30.22	18.0	3.5 4.0	24
16-01	C	30.40	31.47 31.23	30.40 30.23	9.6 10.0	4.8 5.0	24
17-01	C	28.40	29.42 29.45	28.40 28.45	6.0 6.11	4.2 4.07	24
18-01	C	29.40	30.57 30.57	29.40 29.44	6.0 6.09	6.0 6.03	18
19-01	D	22.45	23.87 23.78	22.45 22.45	6.0	9.0 8.01	30
20-01	D	26.30	27.57 27.67	26.30 26.34	7.2	7.3 8.0	30
C-01	C	29.97	30.90 30.94	-	-	-	15
D-01	C	30.32	30.70 30.72	-	-	-	24
F-01	D	30.22	30.43 30.39	-	-	-	18
G-01	D	30.67	30.67	-	-	-	36

- RECORD DRAWING LEGEND**
- 42.00 42.07 PROPOSED/DESIGN ELEVATION OR DIMENSION LINED THROUGH.
 - RECORD ELEVATION OR DIMENSION WRITTEN IN.
 - INDICATES RECORD ELEVATION.
 - INDICATES "RECORD" ELEVATION, DIMENSION, SLOPE, etc.
 - BFP = BLACK FLOW PREVENTOR
 - BO = BLOWOFF
 - NG = NATURAL GROUND
 - A/P = ASPHALT PAVEMENT
 - P.C.P. = PERMANENT CONTROL POINT
 - TON = TOP OF NUT
 - INV. = INVERT

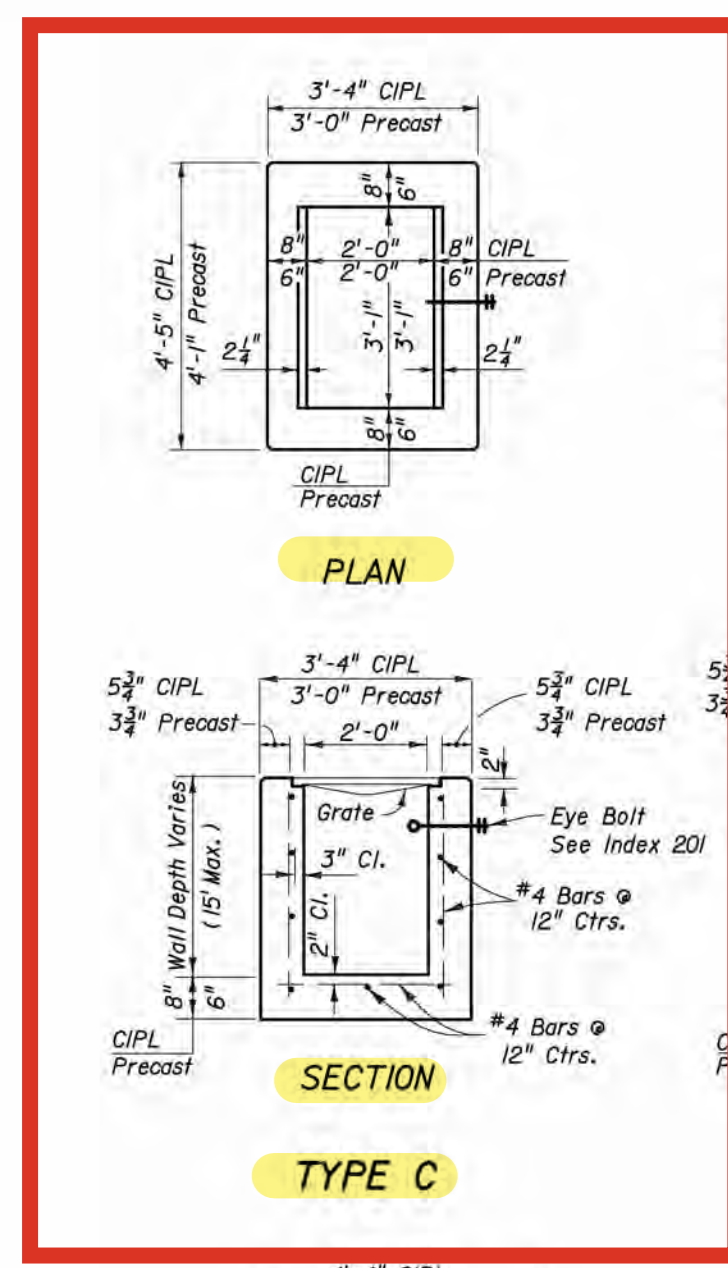

PLAN

SECTION

TYPE C

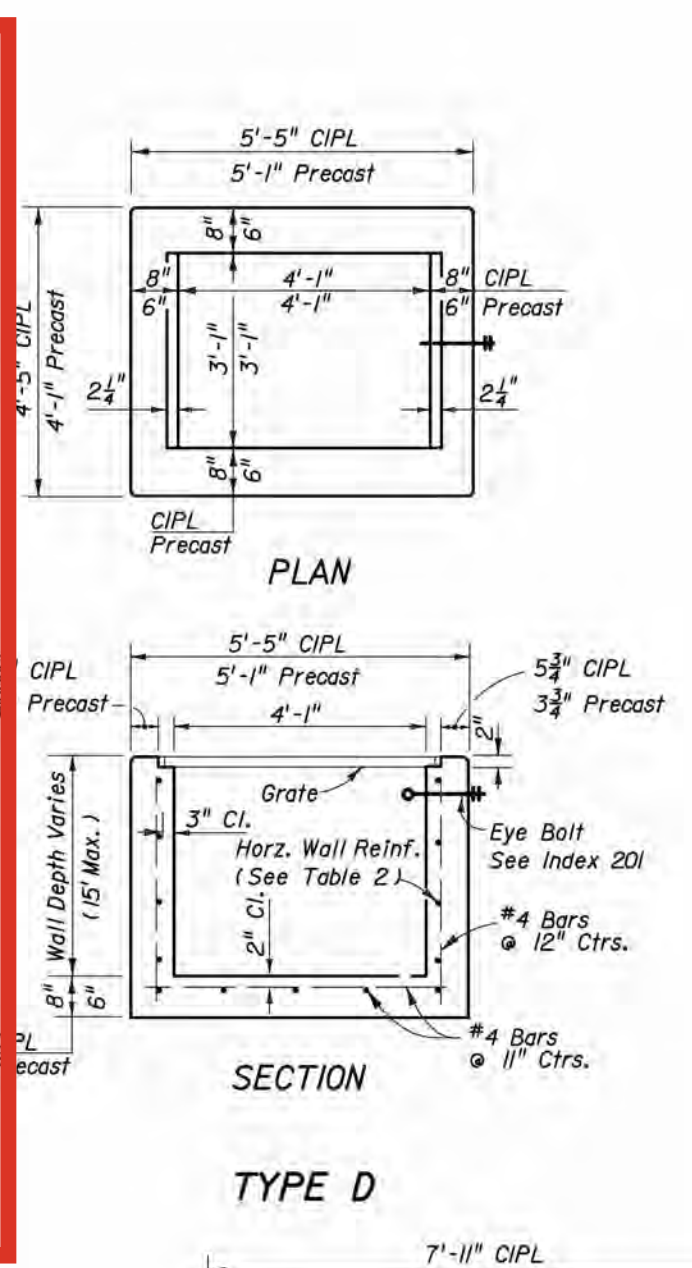

PLAN

SECTION

TYPE D

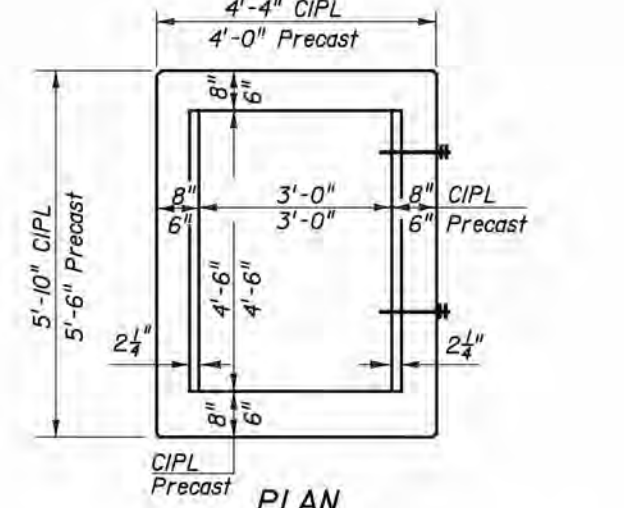

PLAN

SECTION

TYPE E

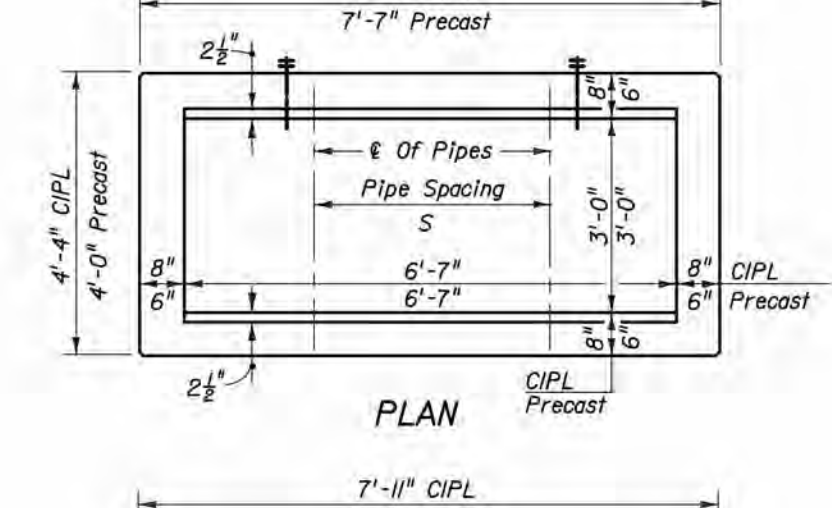

PLAN

SECTION

TYPE H (2 & 3-GRATE INLET)

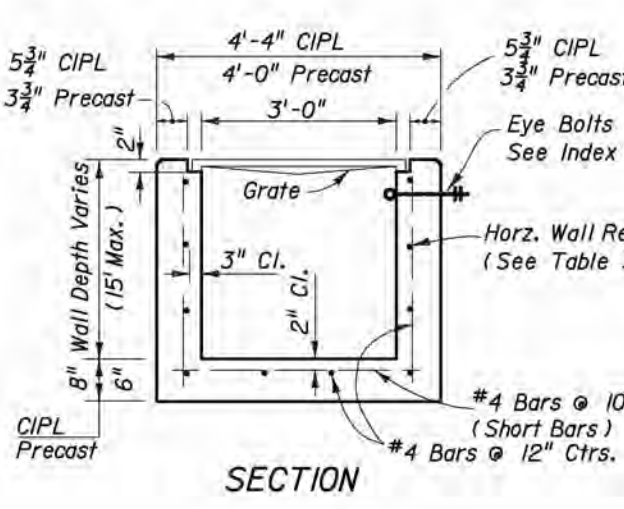

PLAN

SECTION

TYPE E



PLAN

SECTION

DITCH BOTTOM INLETS

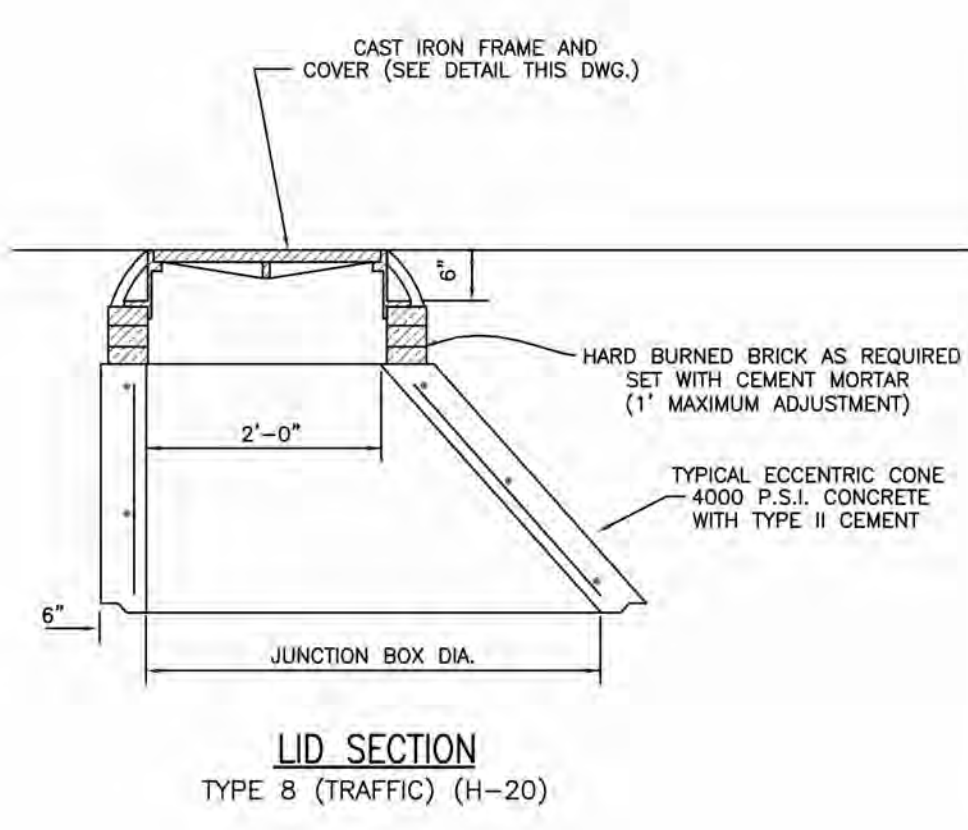

LID SECTION

TYPE B (TRAFFIC) (H-20)

- NOTE:
1. ALL CONCRETE SHALL HAVE A COMPRESSIVE STRENGTH OF AT LEAST 4000 P.S.I. @ 28 DAYS.
 2. REINFORCING SHOWN IS THE MINIMUM REQUIRED. IF DIMENSIONS OF BOX REQUIRES ADDITIONAL REINFORCING IN ORDER TO CARRY DESIGN LOADS, MANUFACTURER SHALL PROVIDE ADDITIONAL REINFORCING AS REQUIRED.

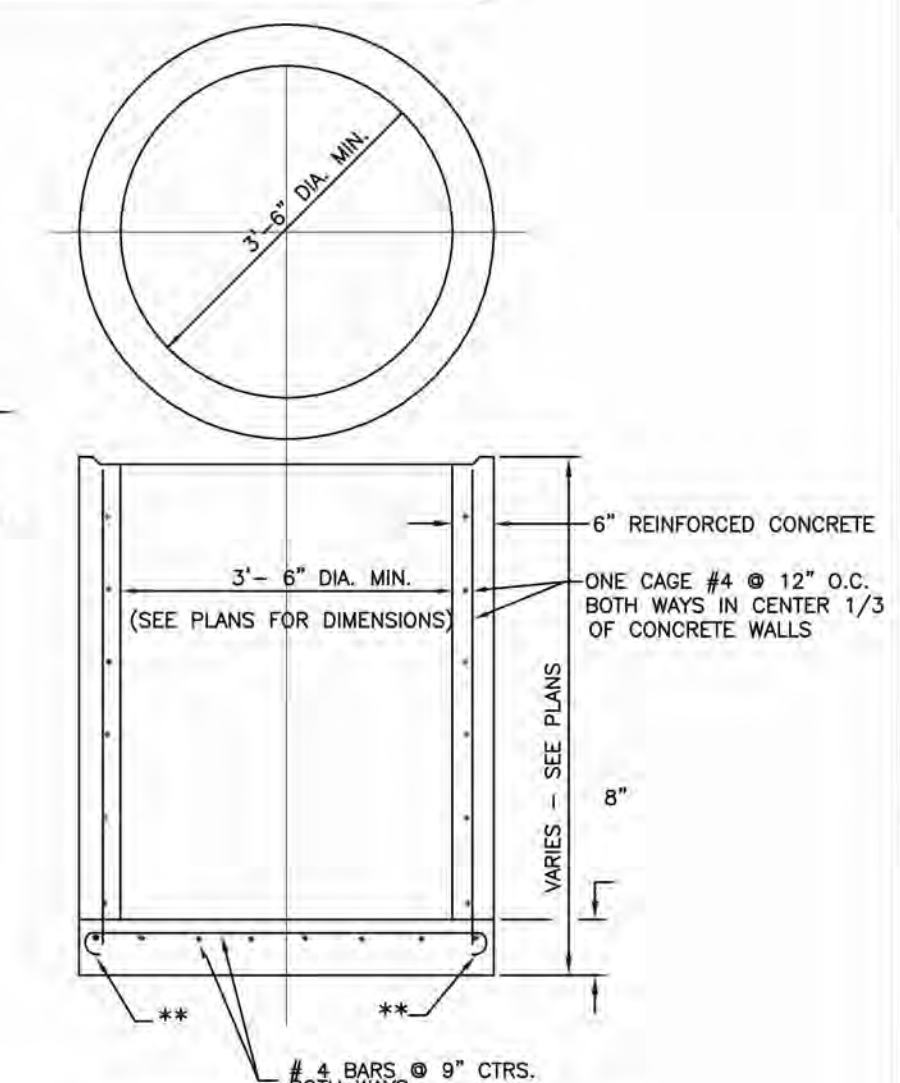

ALTERNATE A

TYPE P

SECTION

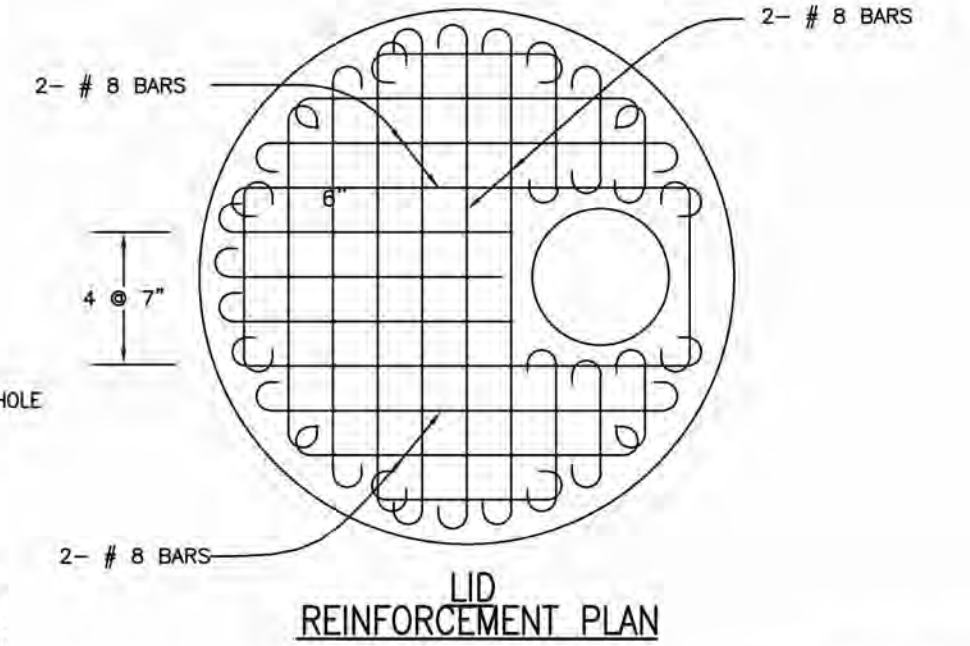

LID REINFORCEMENT PLAN



FRAME AND COVER SECTION

U.S. FOUNDRY 170 H OR APPROVED EQUAL (WHEEL LOAD H-20)

1 FIELD COAT OF ASPHALTIC PAINT FOR FRAME AND COVER

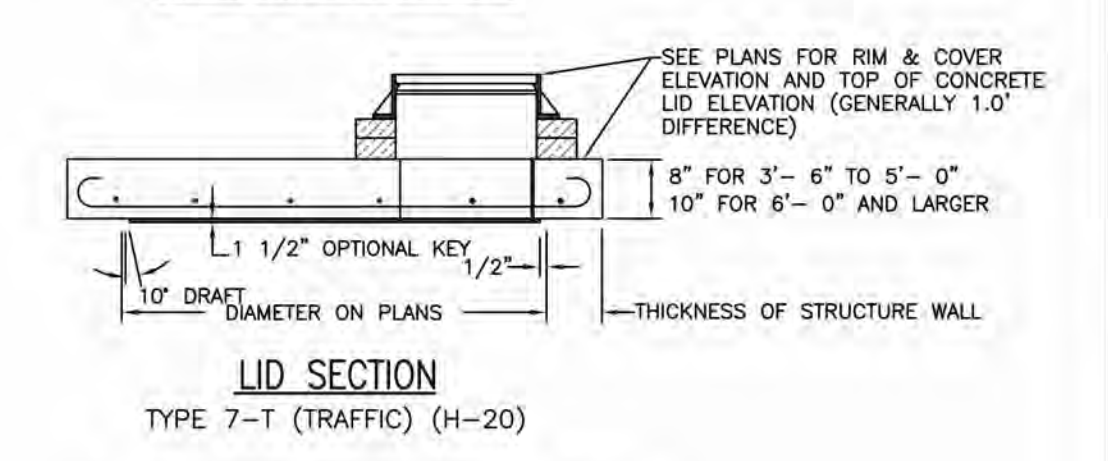

LID SECTION

TYPE 7-T (TRAFFIC) (H-20)

ALL REINFORCEMENT NO. 8 BARS EXCEPT 6-#8 BARS SHOWN BARS SPACED @ 8" CENTERS BOTH WAYS EXCEPT MIDDLE BARS @ 7" CENTERS. ALL BARS WITH ACI STANDARD HOOKS CANTED APPROX. 45°, OR EMBEDDED IN ACCORDANCE WITH THE SLAB REINFORCEMENT DETAIL SHOWN UNDER OPTIONAL CONSTRUCTION JOINTS, SH.T.3 OF 6. EXCEPT ALL #8 BARS AND #6 BARS AROUND MANHOLE OPENING SHALL BE HOOKED.

STANDARD JUNCTION BOX DETAIL

RECORD DRAWINGS

PREPARED FOR:
OK TREVESTA LLC
8875 Hidden River Parkway, Suite 150
Tampa, FL 33637
813-815-1244

MORRIS ENGINEERING AND CONSULTING, LLC
Civil Engineering and Land Development Consulting
6981 Professional Parkway East, Lakewood Ranch, Florida 34201 C.A.28780 941-444-6644 www.morrisengr.com

PRIVATELY MAINTAINED - IRRIGATION SYSTEM
COUNTY MAINTAINED - WATER AND SEWER

NO.	DATE	REVISION DESCRIPTION	BY
09	12/05/16	ADDED RECORD INFORMATION TO SHEETS 1, 4, 8, 11-15, AND 41-43.	SKI
05	08/17/15	REVISED GRAVITY SEWER LAYOUT & MH NUMBERING	IS
04	08/17/15	REVISED: LAKE 11,12,13, VILLAGE C LOT LAYOUT, VILLAGE C ROADWAYS, VILLAGE C GRADING, DRAINAGE, & UTILITIES	IS
03	07/28/15	REVISED SHEET NUMBER (FKA SHEET 39)	IS
02	06/26/15	REVISED SHEET NUMBER (FKA SHEET 37)	IS
01	05/22/15	MISC. REVISIONS PER COUNTY REVIEW	IS

DATE: 02/18/15
PROJECT: TR-P1
DRAWING: EX
DRAWN: GLD
CHECKED: MJM
MATTHEW J. MORRIS
FL LICENSE NO. 68434

PAVING, GRADING, & DRAINAGE DETAILS
TREVESTA - PHASE 1
MANATEE COUNTY, FLORIDA

SCALE 1"=200'
SEC.-TSP.-RNG.
28,33-33S-18E 4-34S-18E

SHEET 42 OF 49

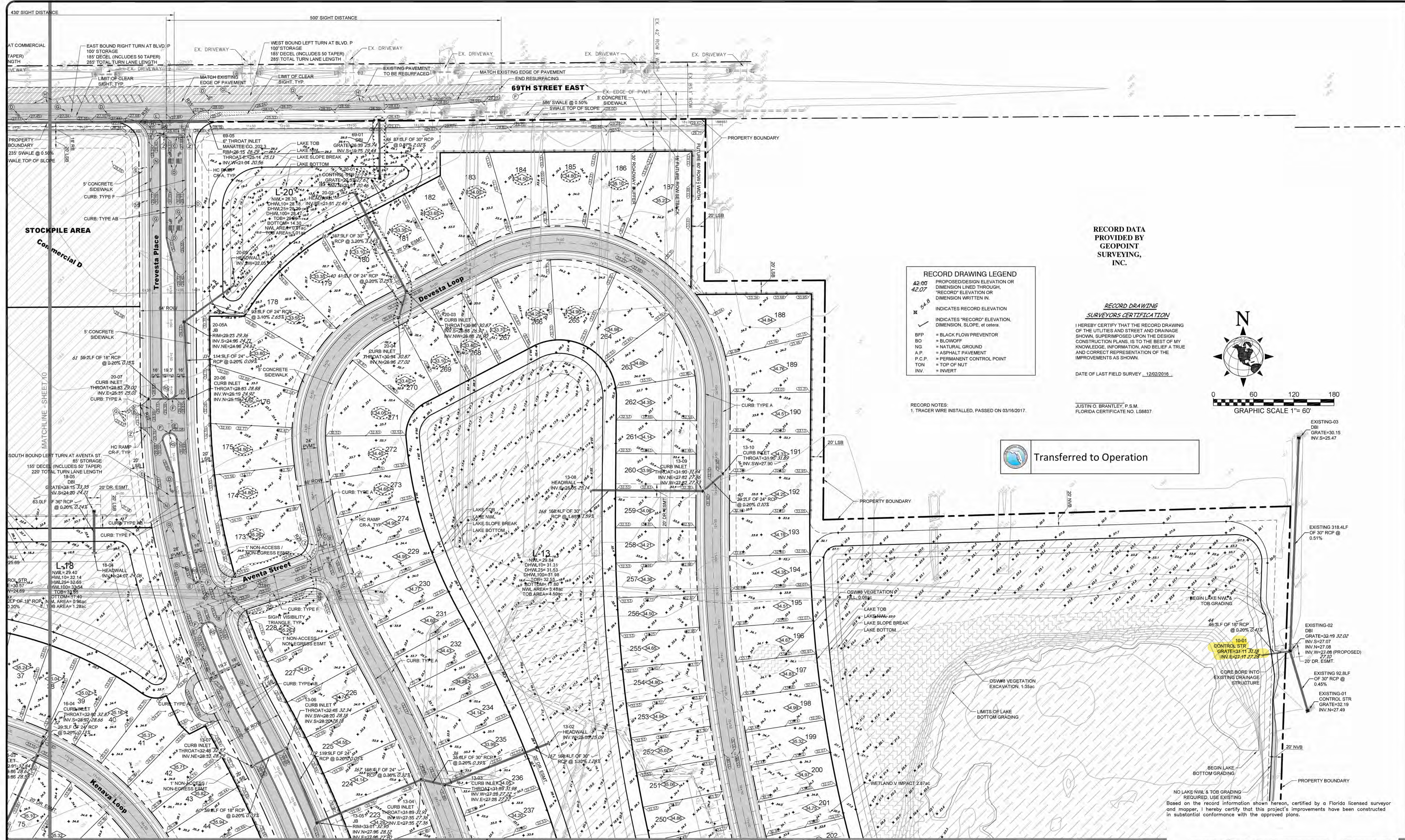

- RECORD DRAWING LEGEND**
- 42.00 PROPOSED DESIGN ELEVATION OR DIMENSION LINED THROUGH.
 - 42.07 "RECORD" ELEVATION OR DIMENSION WRITTEN IN.
 - 54.8 INDICATES RECORD ELEVATION
 - INDICATES "RECORD" ELEVATION, DIMENSION, SLOPE, et cetera.
 - BFP = BLACK FLOW PREVENTOR
 - BO = BLOWOFF
 - NG = NATURAL GROUND
 - A.P. = ASPHALT PAVEMENT
 - P.C.P. = PERMANENT CONTROL POINT
 - T.O.N. = TOP OF NUT
 - INV. = INVERT

RECORD DATA PROVIDED BY GEOPOINT SURVEYING, INC.

RECORD DRAWING SURVEYORS CERTIFICATION

I HEREBY CERTIFY THAT THE RECORD DRAWING OF THE UTILITIES AND STREET AND DRAINAGE SHOWN, SUPERIMPOSED UPON THE DESIGN CONSTRUCTION PLANS IS TO THE BEST OF MY KNOWLEDGE, INFORMATION, AND BELIEF A TRUE AND CORRECT REPRESENTATION OF THE IMPROVEMENTS AS SHOWN.

DATE OF LAST FIELD SURVEY: 12/02/2016

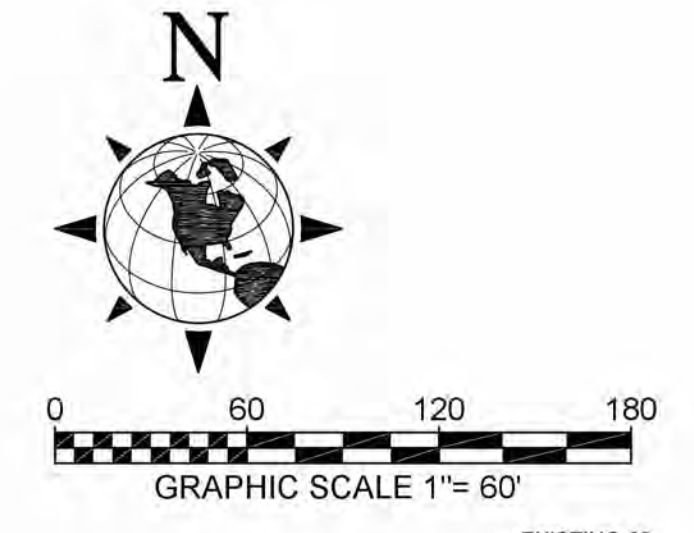

RECORD NOTES:
1. TRACER WIRE INSTALLED, PASSED ON 03/16/2017.

JUSTIN O. BRANTLEY, P.S.M.
FLORIDA CERTIFICATE NO. L58637

Transferred to Operation

- EXISTING-03 DBI GRATE=30.15 INV.S=25.47
- EXISTING-02 DBI GRATE=32.19 32.02 INV.S=27.07 INV.N=27.08 INV.W=27.06 (PROPOSED) INV.E=27.17 27.28 27.10 20' DR. ESMT.
- EXISTING-01 CONTROL STR GRATE=32.19 INV.N=27.49
- EXISTING 92.8LF OF 30" RCP @ 0.45%
- EXISTING 318.4LF OF 30" RCP @ 0.51%

NO LAKE N.W.L. & T.O.B. GRADING REQUIRED, USE EXISTING
Based on the record information shown herein, certified by a Florida licensed surveyor and mapper, I hereby certify that this project's improvements have been constructed in substantial conformance with the approved plans.

Matthew J. Morris, P.E.
Florida License # 68434

RECORD DRAWINGS PRIVATELY MAINTAINED - IRRIGATION SYSTEM COUNTY MAINTAINED - WATER AND SEWER

PREPARED FOR:
OK TREVESTA LLC
8875 Hidden River Parkway, Suite 150
Tampa, FL 33637
813-615-1244

M MORRIS ENGINEERING AND CONSULTING, LLC
Civil Engineering and Land Development Consulting
6981 Professional Parkway East, Lakewood Ranch, Florida 34240 C.A.28780 941-444-6644 www.morrisengineering.net

NO.	DATE	REVISION DESCRIPTION	BY
09	12/05/16	ADDED RECORD INFORMATION TO SHEETS 1, 4, 8, 11-15, AND 41-43	SKJ
05	03/24/16	REVISED LOCATION OF DR. STR.#20-01,69-01,20-02,20-03	IS
04	08/17/15	REVISED LOCATION DEVESTA LOOP LOW POINT FROM 4+15 TO 4+44	IS
		REVISED: LAKE 11,12,613, VILLAGE C LOT LAYOUT, VILLAGE C ROADWAYS, VILLAGE C GRADING, DRAINAGE, & UTILITIES	IS
03	07/22/15	MISC. REVISIONS PER COUNTY REVIEW	IS
02	07/06/15	MISC. REVISIONS PER COUNTY REVIEW	IS
01	05/22/15	MISC. REVISIONS PER COUNTY REVIEW	IS

DATE: 02/18/15
PROJECT: TR-P1
DRAWING: PGD
DRAWN: GLD
CHECKED: MJM

PAVING, GRADING, & DRAINAGE PLAN
TREVESTA - PHASE 1
MANATEE COUNTY, FLORIDA

SCALE: 1"=60'
SEC. - TSP, -RNG.
28,33-335-18E 4-345-18E

SHEET 11 OF 49

Trevesta CDD Pond 10 Repairs Proposal



Repair Process and Finished Product

The repair for the bank will consist of the installation of an erosion control filter fabric, 6-12" limestone rip rap, imported fill soil, and Bahia sod. The rock will be installed to create a new non-erodible toe of slope. Rip rap will be visible above the water line except during times of exceptionally high water levels. Pond will be brought to a 3:1 slope throughout rip rap area and 5:1 slope above rip rap to top of bank at project finish. In order to provide the highest quality repair, Finn Outdoor will remove the majority of vegetation from the near-vertical eroded areas and will cut and fill several areas along the bank to remove the most severe variations in the bank. This also includes stripping, filling, and compacting any low spots which could ultimately undermine the finished repair. All staging and access areas will be repaired by



stripping turf, grading or filling, and installing new turf as necessary. Any damage to irrigation, sidewalks, or curbs due to the repair process will be repaired. All work will conform to the notes and drawings provided by Stantec in the memo/request labeled *Project/File: Pond 10 Erosion Review*

Staging and Access

Per Stantec’s direction materials will be staged in the CDD owned area to the North of the “Future Repairs” section on the map. Access for repairs will be through easement near the repair area at 5724/5806 Hevena Ct. Any damage to turf, landscaping, irrigation, etc will be repaired.

Construction Schedule

Total project is expected to take approximately 2 weeks. As of 5/12/2026 our schedule would allow for a start date for this project on or about 7/1/2026

Warranty

Finn Outdoor will warranty all parts of the project, except sod, for a period of three years. Sod will be guaranteed to be healthy and viable and to be of appropriate species for the conditions, however no further guarantee of the future growth or health of the sod is offered. Sod will be watered by Finn Outdoor during project duration. Water, fertilizer, pesticide, or any other care to ensure successful establishment of the sod will be the responsibility of the CDD once cleanup and access repairs are completed.

Compensation

Total compensation for this project will be \$59,500 and will be requested in two draws; 33% as a down payment and 67% invoiced upon completion and due within 30 days.

Previous Similar Work: Greenfield Plantation, Bradenton



Erosion and Stormwater Specialists
Wetland Mitigation
Drainage Solutions



730 20th Ave N
St Petersburg, FL 33704
813.957.6075
robb@finnoutdoor.com
www.finnoutdoor.com

Previous Similar Work: Beekman Lakes, Sarasota



Previous Similar Work: South Fork, Riverview





Proposal for Pond Bank Erosion Repair & Site Restoration

Prepared For: Trevesta CDD

Contractor: Advanced Drainage Solutions (ADS)

Date Created: 05/22/2026

Proposal No. : 1260

Project Location: Trevesta (Pond 10)

Project Overview & Scope of Work

This project includes repairing approximately 420 linear feet of eroded pond bank through excavation, installation of filter fabric and rip rap stabilization, placement of compacted fill, and slope restoration. Work also includes mobilization, erosion control, sod replacement, sidewalk and irrigation repairs as needed, and final site cleanup to restore all disturbed areas to existing conditions.

1. Mobilization & Site Preparation

- Mobilize crews, excavation equipment, trucking, and support materials.
- Coordinate access route and staging area.
- Implement erosion and sediment control measures as required.

2. Pond Bank Erosion Repair (420 LF)

- Excavate and prepare failed/eroded pond bank sections.
- Install filter fabric along repair areas.
- Furnish and place rip rap armor stone along the pond bank per provided concept detail.
- Place and compact suitable fill material behind rip rap.
- Fine grade repaired slopes to proposed elevations and contours.

3. Sod Restoration

- Replace disturbed sod within access easement areas.
- Replace disturbed sod within staging areas.
- Restore all disturbed turf areas with new St. Augustine sod to match existing conditions.

4. Sidewalk & Surface Restoration

- Remove and replace damaged sidewalk panels impacted by trucking operations.
- Restore any damaged irrigation components impacted by construction activities.
- Match existing concrete finish and thickness where repairs are required.

5. Cleanup

- Remove excess material, debris, and construction waste from site.
- Final dress and cleanup of all work areas.

Exclusions

Project pricing excludes permit fees, surveying, dewatering, utility relocation, environmental permitting, night or weekend work, fence removal/replacement, landscape replacement beyond sod, repairs to erosion outside identified limits, and watering of newly installed sod.

Schedule

The estimated project duration is approximately 2–3 weeks. Scheduling is subject to weather conditions, material availability, and coordination of site access with the HOA.

Project Cost: \$119,000.00

Workmanship Warranty

ADS LLC warrants that all work performed under this proposal will be free from defects in workmanship for a period of one (1) year from the date of completion. This warranty covers installation and labor only and does not include damage caused by unforeseen conditions or factors beyond contractor control.

Accepted date

Accepted by

Tab 6



Rizzetta & Company

UPCOMING DATES TO REMEMBER

- **Next Meeting:** August 12, 2026
- **Next Election:** November 2026

**District
Manager's
Report**

June 3,

2026

T
R
E
V
E
S
T
A

C
D
D

<u>FINANCIAL SUMMARY</u>	<u>04/30/2026</u>
General Fund Cash & Investment Balance:	\$783,869
Reserve Fund Cash & Investment Balance:	\$196,221
Debt Service Fund Investment Balance:	<u>\$1,899,100</u>
Total Cash and Investment Balances:	\$2,879,190
General Fund Expense Variance: \$129,930	Under budget

Tab 7

Scott Farrington

Supervisor of Elections



**MAKE FREEDOM COUNT...
REGISTER AND VOTE!**

Manatee County, Florida

April 15, 2026

Trevesta Community Development District
Attn: Sam Stevens
2700 S Falkenburg Rd Suite 2745
Riverview FL 33578

Dear Sam Stevens:

Per your request for the number of registered voters in the Trevesta Community Development District as of April 15, 2026. According to our records, there were 1352 persons registered in the Trevesta Community Development District as of that date.

I hope this information is helpful to you. If I can be of any further assistance to you, please do not hesitate to contact my office at your earliest convenience.

Sincerely,

Scott Farrington
Supervisor of Elections

SF/sas

Tab 8

RESOLUTION 2026-03

A RESOLUTION OF THE BOARD OF SUPERVISORS OF THE TREVESTA COMMUNITY DEVELOPMENT DISTRICT APPROVING A PROPOSED BUDGET FOR FISCAL YEAR 2027 AND SETTING A PUBLIC HEARING THEREON PURSUANT TO FLORIDA LAW; ADDRESSING TRANSMITTAL, POSTING AND PUBLICATION REQUIREMENTS; ADDRESSING SEVERABILITY; AND PROVIDING AN EFFECTIVE DATE.

WHEREAS, the District Manager has, prior to June 15, 2026, prepared and submitted to the Board of Supervisors (“**Board**”) of the Trevesta Community Development District (“**District**”) a proposed budget (“**Proposed Budget**”) for the Fiscal Year beginning October 1, 2026, and ending September 30, 2027 (“**Fiscal Year 2027**”); and

WHEREAS, the Board has considered the Proposed Budget and desires to set the required public hearing thereon.

NOW, THEREFORE, BE IT RESOLVED BY THE BOARD OF SUPERVISORS OF THE TREVESTA COMMUNITY DEVELOPMENT DISTRICT:

1. **PROPOSED BUDGET APPROVED.** The Proposed Budget prepared by the District Manager for Fiscal Year 2027 attached hereto as **Exhibit A** is hereby approved as the basis for conducting a public hearing to adopt said Proposed Budget.

2. **SETTING A PUBLIC HEARING.** A public hearing on said approved Proposed Budget is hereby declared and set for the following date, hour and location:

DATE: _____, 2026

HOUR: 3:00 p.m.

LOCATION: Trevesta Clubhouse
6120 Trevesta Place
Palmetto, Florida 34221

3. **TRANSMITTAL OF PROPOSED BUDGET TO LOCAL GENERAL PURPOSE GOVERNMENT.** The District Manager is hereby directed to submit a copy of the Proposed Budget to Manatee County, Florida at least sixty (60) days prior to the hearing set above.

4. **POSTING OF PROPOSED BUDGET.** In accordance with Section 189.016, *Florida Statutes*, the District’s Secretary is further directed to post the approved Proposed Budget on the District’s website at least two (2) days before the budget hearing date as set forth in Section 2, and shall remain on the website for at least forty-five (45) days.

5. **PUBLICATION OF NOTICE.** Notice of this public hearing shall be published in the manner prescribed in Florida law.

6. **SEVERABILITY.** The invalidity or unenforceability of any one or more provisions of this Resolution shall not affect the validity or enforceability of the remaining portions of this Resolution, or any part thereof.

7. **EFFECTIVE DATE.** This Resolution shall take effect immediately upon adoption.

PASSED AND ADOPTED THIS 3rd DAY OF JUNE, 2026.

ATTEST:

**TREVESTA COMMUNITY
DEVELOPMENT DISTRICT**

Secretary

By: _____
Its: _____

Exhibit A: Proposed Budget for Fiscal Year 2027

RESOLUTION 2026-03

A RESOLUTION OF THE BOARD OF SUPERVISORS OF THE TREVESTA COMMUNITY DEVELOPMENT DISTRICT APPROVING A PROPOSED BUDGET FOR FISCAL YEAR 2027; DECLARING SPECIAL ASSESSMENTS TO FUND THE PROPOSED BUDGET PURSUANT TO CHAPTERS 190, 197, AND 170, FLORIDA STATUTES; SETTING PUBLIC HEARINGS; ADDRESSING PUBLICATION; ADDRESSING SEVERABILITY; AND PROVIDING AN EFFECTIVE DATE.

WHEREAS, the District Manager has, prior to June 15, 2026, prepared and submitted to the Board of Supervisors (“**Board**”) of the Trevesta Community Development District (“**District**”) a proposed budget (“**Proposed Budget**”) for the Fiscal Year beginning October 1, 2026, and ending September 30, 2027 (“**Fiscal Year 2027**”); and

WHEREAS, it is in the best interest of the District to fund the administrative and operations services (together, “**Services**”) set forth in the Proposed Budget by levy of special assessments pursuant to Chapters 190, 197, and/or 170, *Florida Statutes* (“**Assessments**”), as set forth in the preliminary assessment roll included within the Proposed Budget; and

WHEREAS, the District hereby determines that benefits would accrue to the properties within the District, as outlined within the Proposed Budget, in an amount equal to or in excess of the Assessments, and that such Assessments would be fairly and reasonably allocated as set forth in the Proposed Budget; and

WHEREAS, the Board has considered the Proposed Budget, including the Assessments, and desires to set the required public hearings thereon.

NOW, THEREFORE, BE IT RESOLVED BY THE BOARD OF SUPERVISORS OF THE TREVESTA COMMUNITY DEVELOPMENT DISTRICT:

1. PROPOSED BUDGET APPROVED. The Proposed Budget prepared by the District Manager for Fiscal Year 2027 attached hereto as **Exhibit A** is hereby approved as the basis for conducting a public hearing to adopt said Proposed Budget.

2. DECLARING ASSESSMENTS. Pursuant to Chapters 190, 197, and 170, *Florida Statutes*, the Assessments shall defray the cost of the Services in the total estimated amounts set forth in the Proposed Budget. The nature of, and plans and specifications for, the Services to be funded by the Assessments are described in the Proposed Budget, which is on file and available for public inspection at the “**District’s Office**,” Rizzetta & Company, Inc., 2700 S. Falkenburg Road, Suite 2745, Riverview, Florida 33578. The Assessments shall be levied within the District on all benefitted lots and lands, and shall be apportioned among such lots and lands, all as described in the Proposed Budget and the preliminary assessment roll included therein. The preliminary assessment roll is also on file and available for public inspection at the District’s Office. The Assessments shall be paid in one or more installments pursuant to a bill issued by the District in November of 2026, and pursuant to Chapter 170, *Florida Statutes*, or, alternatively, pursuant to the *Uniform Method* as set forth in Chapter 197, *Florida Statutes*.

3. SETTING PUBLIC HEARINGS. Pursuant to Chapters 190, 197, and 170, *Florida Statutes*, public hearings on the approved Proposed Budget and the Assessments are hereby declared and set for the following date, hour and location:

DATE: _____, 2026

HOUR: 3:00 p.m.

LOCATION: Trevesta Clubhouse
6120 Trevesta Place
Palmetto, Florida 34221

4. TRANSMITTAL OF PROPOSED BUDGET TO LOCAL GENERAL PURPOSE GOVERNMENT. The District Manager is hereby directed to submit a copy of the Proposed Budget to Manatee County, Florida at least sixty (60) days prior to the hearing set above.

5. POSTING OF PROPOSED BUDGET. In accordance with Section 189.016, *Florida Statutes*, the District’s Secretary is further directed to post the approved Proposed Budget on the District’s website at least two (2) days before the budget hearing date as set forth in Section 3 and shall remain on the website for at least forty-five (45) days.

6. PUBLICATION OF NOTICE. The District shall cause this Resolution to be published once a week for a period of two (2) weeks in a newspaper of general circulation published in Manatee County. Additionally, notice of the public hearings shall be published in the manner prescribed in Florida law.

7. SEVERABILITY. The invalidity or unenforceability of any one or more provisions of this Resolution shall not affect the validity or enforceability of the remaining portions of this Resolution, or any part thereof.

8. EFFECTIVE DATE. This Resolution shall take effect immediately upon adoption.

PASSED AND ADOPTED THIS 3rd DAY OF JUNE, 2026.

ATTEST:

**TREVESTA COMMUNITY
DEVELOPMENT DISTRICT**

Secretary

By: _____
Its: _____

Exhibit A: Proposed Budget for Fiscal Year 2027

Tab 9

RESOLUTION 2026-04

A RESOLUTION OF THE BOARD OF SUPERVISORS OF THE TREVESTA COMMUNITY DEVELOPMENT DISTRICT ELECTING THE OFFICERS OF THE TREVESTA COMMUNITY DEVELOPMENT DISTRICT AND PROVIDING FOR AN EFFECTIVE DATE.

WHEREAS, the Trevesta Community Development District (“**District**”), is a local unit of special-purpose government created and existing pursuant to Chapter 190, *Florida Statutes*, being situated entirely within Manatee County, Florida; and

WHEREAS, the Board of Supervisors of the District (“**Board**”) desires to elect the Officers of the District.

NOW, THEREFORE, BE IT RESOLVED BY THE BOARD OF SUPERVISORS OF THE TREVESTA COMMUNITY DEVELOPMENT DISTRICT:

SECTION 1. The following persons are elected to the offices shown:

Section 1. **Dave Hoyt**_____ is appointed Chairperson.

Section 2. William Dornetto_____ is appointed Vice Chairperson.

Section 3. Dean Lafollette_____ is appointed Assistant Secretary.

Joseph Powlis_____ is appointed Assistant Secretary.

Theodore Piwowar_____ is appointed Assistant Secretary.

Sam Stevens_____ is appointed Assistant Secretary.

Matthew O’Nolan_____ is appointed Assistant Secretary.

Scott Brizendine_____ is appointed Secretary.

Scott Brizendine_____ is appointed Treasurer.

Susan Garcia_____ is appointed Assistant Treasurer.

SECTION 2. This Resolution shall become effective immediately upon its adoption.

PASSED AND ADOPTED this 3rd day of June 2026.

ATTEST:

**TREVESTA COMMUNITY
DEVELOPMENT DISTRICT**

Secretary/Assistant Secretary

Chairperson/Vice Chairperson,
Board of Supervisors

Tab 10



LLS Tax Solutions Inc.
1645 Sun City Center Plz,
#5027
Sun City Center, FL 33571
Telephone: 850-754-0311
Email: liscott@llstax.com

April 20, 2026

Trevesta Community Development District
c/o Rizzetta & Company, Inc.
3434 Colwell Avenue, Suite 200
Tampa, Florida 33614

Thank you for choosing LLS Tax Solutions Inc. (“LLS Tax”) to provide arbitrage services to Trevesta Community Development District (“Client”) for the following bond issue. This Engagement Letter describes the scope of the LLS Tax services, the respective responsibilities of LLS Tax and Client relating to this engagement and the fees LLS Tax expects to charge.

- \$4,925,000 Trevesta Community Development District Special Assessment Bonds, Series 2016A-1
- \$3,350,000 Trevesta Community Development District Special Assessment Bonds, Series 2016A-2

SCOPE OF SERVICES

The procedures that we will perform are as follows:

- Assist in calculation of the bond yield, unless previously computed and provided to us.
- Assist in determination of the amount, if any, of required rebate to the federal government.
- Issuance of a report presenting the cumulative results since the issue date of the issue of bonds.
- Preparation of necessary reports and Internal Revenue Service (“IRS”) forms to accompany any required payment to the federal government.

As a part of our engagement, we will read certain documents associated with each issue of bonds for which services are being rendered. We will determine gross proceeds of each issue of bonds based on the information provided in such bond documents. You will have sole responsibility for determining any other amounts not discussed in those documents that may constitute gross proceeds of each series of bonds for the purposes of the arbitrage requirements.

TAX POSITIONS AND REPORTABLE TRANSACTIONS

Because the tax law is not always clear, we will use our professional judgment in resolving questions affecting the arbitrage calculations. Unless you instruct us otherwise, we will take the reporting position most favorable to you whenever reasonable. Any of your bond issues may be selected for review by the IRS, which may not agree with our positions. Any proposed adjustments are subject to certain rights of appeal. Because of the lack of clarity in the law, we cannot provide assurances that

the positions asserted by the IRS may not ultimately be sustained, which could result in the assessment of potential penalties. You have the ultimate responsibility for your compliance with the arbitrage laws; therefore, you should review the calculations carefully.

The IRS and some states have promulgated “tax shelter” rules that require taxpayers to disclose their participation in “reportable transactions” by attaching a disclosure form to their federal and/or state income tax returns and, when necessary, by filing a copy with the Internal Revenue Service and/or the applicable state agency. These rules impose significant requirements to disclose transactions and such disclosures may encompass many transactions entered into in the normal course of business. Failure to make such disclosures will result in substantial penalties. In addition, an excise tax is imposed on exempt organizations (including state and local governments) that are a party to prohibited tax shelter transactions (which are defined using the reportable transaction rules). Client is responsible for ensuring that it has properly disclosed all “reportable transactions” and, where applicable, complied with the excise tax provision. The LLS Tax services that are the subject of this Engagement Letter do not include any undertaking by LLS Tax to identify any reportable transactions that have not been the subject of a prior consultation between LLS Tax and Client. Such services, if desired by Client, will be the subject of a separate engagement letter. LLS Tax may also be required to report to the IRS or certain state tax authorities certain tax services or transactions as well as Client’s participation therein. The determination of whether, when and to what extent LLS Tax complies with its federal or state “tax shelter” reporting requirements will be made exclusively by LLS Tax. LLS Tax will not be liable for any penalties resulting from Client’s failure to accurately and timely file any required disclosure or pay any related excise tax nor will LLS Tax be held responsible for any consequences of its own compliance with its reporting obligations. Please note that any disclosure required by or made pursuant to the tax shelter rules is separate and distinct from any other disclosure that Client might be required to or choose to make with its tax returns (e.g., disclosure on federal Form 8275 or similar state disclosure).

PROFESSIONAL FEES AND EXPENSES

Our professional fees for the services listed above for the three annual bond years beginning March 29, 2025, through the period ended March 28, 2028, is \$1,500, which is \$500 for each year. We will bill you upon completion of our services. Our invoices are payable upon receipt. Additionally, you may request additional consulting services from us upon occasion; we will bill you for these consulting services at a beforehand agreed upon rate.

Unanticipated factors that could increase our fees beyond the estimate given above include the following (without limitation). Should any of these factors arise we will alert you before additional fees are incurred.

- Investment data provided by you is not in good order or is unusually voluminous.
- Proceeds of bonds have been commingled with amounts not considered gross proceeds of the bonds (if that circumstance has not previously been communicated to us).
- A review or other inquiry by the IRS with respect to an issue of bonds.

The Client (District) has the option to terminate this Agreement within ninety days of providing notice to LLS Tax Solutions Inc. of its intent.

ACCEPTANCE

You understand that the arbitrage services, report and IRS forms described above are solely to assist you in meeting your requirements for federal income tax compliance purposes. This Engagement Letter constitutes the entire agreement between Client and LLS Tax with respect to this engagement, supersedes all other oral and written representations, understandings or agreements relating to this engagement, and may not be amended except by the mutual written agreement of the Client and LLS Tax.

Please indicate your acceptance of this agreement by signing in the space provided below and returning a copy of this Engagement Letter to us. Thank you again for this opportunity to work with you.

Very truly yours,
LLS Tax Solutions Inc.

AGREED AND ACCEPTED:
Trevesta Community Development District

By: Linda L. Scott
Linda L. Scott, CPA

By: _____
Print Name _____
Title _____
Date: _____

Tab 11



11120 S US HWY 41
 Gibsonton, FL 33534
 (813) 999-2219

ESTIMATE

EST-4695

We are SERVICE oriented!
<http://www.fastsigns.com/2448>

Payment Terms: Net 7

Created Date: 4/28/2026

DESCRIPTION: No Fishing Signs (3)

Bill To: Trevesta CDD
 2700 S Falkenburg Road
 Suite 2745
 Riverview, FL 33578
 US

Installed: Trevesta CDD
 TREVESTA
 6120 Trevesta Place
 Palmetto, FL 34221
 US

Requested By: Sam Stevens
 Email: sstevens@rizzetta.com
 Work Phone: (813) 533-2950
 Tax ID: 85-801678288C-6

Salesperson: Thomas Green
 Email: thomas.green@fastsigns.com

NO.	Product Summary	QTY	UNIT PRICE	TAXABLE	AMOUNT
1	NO FISHING SIGNS Maxmetal- 3mm White, 12W"x18H"(3) SS	3	\$122.18	\$0.00	\$366.54
1.1.1	Max Metal 3mm - Max Metal/ACM 3mm Part Qty: 1 Width: 12.00" Height: 18.00" Sides: 1 Text: NO FISHING Notes: White background Black Border fish image with Red slash zero around it (see attached image)				
1.1.2	Avery Dennison 2903 (Cal) - Avery Dennison 2903 (Cal) Part Qty: 1 Width: 12.00" Height: 18.00" - Vinyl Only, Applied to Substrate,				
1.1.3	OL ARLON 3420G GLOSS CLEAR (Cal) - ARLON 3420G GLOSS CLEAR (Cal) Part Qty: 1 Width: 12.00" Height: 18.00"				
1.2	U-Channel Sign Post - Green 8' - U-Channel Sign Post - Green 8' Part Qty: 1				
1.3	Installation - Installation - Number of Installers: 1 - # of Hours: 0.34				

ALL PRODUCTS produced by FASTSIGNS of Riverview remain the sole property of FASTSIGNS of Riverview until final payment has cleared.

This ESTIMATE is good for 7 days.

We appreciate your business.

Base Subtotal:	\$366.54
Shipping:	\$79.20
Subtotal:	\$445.74
Taxable Amount:	\$0.00
Taxes:	\$0.00
Grand Total:	\$445.74
<i>Credit Card Surcharge:</i>	3.00%
<i>Total with Surcharge:</i>	\$459.11

FOR ALL INSTALLATIONS: Electrical to the location of the installation is the responsibility of the customer unless explicitly listed in this estimate. Any agreements verbal or otherwise are superseded by this estimate.

All installations are subject to a required site survey. Final pricing, timeline, and scope of work may be adjusted based on site conditions and survey findings.

Measurements, specifications, and product performance are the responsibility of the customer unless verified in person by a FASTSIGNS of Riverview team member.

ENGINEERING, PERMITS and INSPECTIONS are the responsibility of the customer unless specifically listed in this ESTIMATE.

Signature: _____ **Date:** _____

Tab 12



Mailing: PO Box 917 Parrish, FL 34219
Physical: 11719 31st TER E Palmetto, FL 34221

813.558.2125
www.sitexaquatics.com

Aquatic Midge Management Agreement

This agreement is between Sitex Aquatics, LLC. Hereafter called Sitex and Trevesta CDD hereafter called "customer"

Customer: Trevesta CDD
C/O: Rizzetta & Company
Contact: Mr. Matt O’Nolan
Address: 12750 Citrus Park lane Suite 115 Tampa, FL 33625
Email: Monolan@rizzetta.com
Phone: 813.793.8814

Sitex agrees to provide aquatic midge fly management services for a period of 10 months In accordance with the terms and conditions of this agreement in the following sites:

Seven (7) Pond banks located at the Trevesta Community in Ellenton, FL (see attached map)

Customer agrees to pay Sitex the following amounts during the term of this agreement for the specific service:

- 1. *Monthly Larvicide for aquatic Midge Fly's* *Included*
- 2. *All Services Performed by State Licensed Applicator* *Included*

Service shall consist of 7 Monthly treatments (May-Nov)

Customer agrees to pay Sitex the following amount during the term of this agreement which shall be for 7 months. Agreement will automatically renew as per Term and Conditions:

Pond #3 \$1,288.00
Pond #4 \$2,485.00
Pond #7 \$1,211.00
Pond #11 \$3,955.00
Pond #13 \$2,296.00
Pond #15 \$1,715.00
Pond #16 \$1,610.00

Monthly Service Amount: \$2,080.00
Total 7 month Cost: \$14,560.00

Invoice is due and payable within 30 days. Overdue accounts may accrue a service charge.

Customer acknowledges that he/she has read and is familiar with the additional terms and conditions printed on the reverse side, which are incorporated in this agreement.

<u>Dave Hoyt</u> <small>Dave Hoyt (May 11, 2026 07:10:33 EDT)</small>	11/05/2026	 _____ President, Sitex Aquatics Ilc.	05/04/2026
Accepted By	Date	Date	Date

Terms & Conditions

Sitex agrees to provide all labor, supervision, and equipment necessary to carry out the work. There shall be no variance from these specifications unless expressly stated through an addendum.

The Annual Cost will be paid to Sitex in Seven (7) equal payments, which are due and payable in advance of each month in which the service will be rendered and will be considered late on the 30th of that month. A surcharge of two percent (2%) per month will be added for delinquent payments. The Customer is responsible for any collection or attorney's fees required to collect on this agreement.

This Agreement will be for a Seven (7) month period. This Agreement shall be automatically renewed at the end of the three (3) months. The monthly service amount may be adjusted, as agreed upon by both Parties, and set forth in writing to Customer. Both parties agree that service shall be continuous without interruption.

Additional Services requested by the customer such as trash clean up, physical cutting or paint removal, and other additional services performed will be billed separately at the current hourly equipment and labor rates.

Cancellation by either the Customer or Sitex may terminate the Agreement without cause at any time. Termination shall be by written notice, received by either the customer or Sitex at least thirty (30) days prior to the effective date of the termination.

Neither party shall be responsible for damage, penalties or otherwise for any failure or delay in performance of any of its obligations hereunder caused by strikes, riots, war, acts of Nature, accidents, governmental orders and regulations, curtailment or failure to obtain sufficient material, or other force majeure condition (whether or not of the same class or kind as those set forth above) beyond its reasonable control and which, by the exercise of due diligence, it is unable to overcome. • Sitex agrees to hold Customer harmless from any loss, damage or claims arising out of the sole negligence of Sitex. However, Sitex shall in no event be liable to Customer or other for indirect, special or consequential damage resulting from any cause whatsoever.

It is agreed by both Parties that the work performed under this Agreement will be done on a schedule that is sensitive to the overall function of the property. Additionally, it is understood that all work will be performed during the normal business week (Monday-Friday) unless otherwise stipulated.

Sitex shall maintain the following insurance coverage and limits;

- (a) Workman's Compensation with statutory limits;
- (b) Automobile Liability;
- (c) Comprehensive General Liability including Property Damage, Completed Operations, and Product Liability.

A Certificate of insurance will be provided upon request. Customers requesting special or additional insurance coverage and/or language shall pay resulting additional premium to Sitex to provide such coverage. • This Agreement shall be governed by the laws of the state of Florida.





Trevesta NTE Midge

Final Audit Report

2026-05-11

Created:	2026-05-08
By:	Sam Stevens (sstevens@rizzetta.com)
Status:	Signed
Transaction ID:	CBJCHBCAABAA0AbADqIY6pEPxwh8leAiZ4tHCJ0atRc9

"Trevesta NTE Midge" History

-  Document created by Sam Stevens (sstevens@rizzetta.com)
2026-05-08 - 1:16:14 PM GMT
-  Document emailed to Dave Hoyt (dhoyt@trevestacdd.org) for signature
2026-05-08 - 1:16:17 PM GMT
-  Email viewed by Dave Hoyt (dhoyt@trevestacdd.org)
2026-05-11 - 11:09:48 AM GMT
-  Document e-signed by Dave Hoyt (dhoyt@trevestacdd.org)
Signature Date: 2026-05-11 - 11:10:33 AM GMT - Time Source: server - Signature Appearance Selected: TYPE
-  Agreement completed.
2026-05-11 - 11:10:33 AM GMT

Tab 13

Tab 14



Rizzetta & Company

Trevesta Community Development District

**Financial Statements
(Unaudited)**

March 31, 2026

Prepared by: Rizzetta & Company, Inc.

trevestacdd.org
rizzetta.com

Trevesta Community Development District

Balance Sheet

As of 03/31/2026

(In Whole Numbers)

	General Fund	Reserve Fund	Debt Service Fund	Capital Project Fund	Total Gvmnt Fund	Fixed Assets Group	Long-Term Debt
Assets							
Cash In Bank	800,622	0	0	0	800,622	0	0
Investments	0	195,698	1,893,428	21,375	2,110,502	0	0
Accounts Receivable	35,079	0	23,427	0	58,505	0	0
Refundable Deposits	3,710	0	0	0	3,710	0	0
Fixed Assets	0	0	0	0	0	17,138,593	0
Amount Available in Debt Service	0	0	0	0	0	0	1,916,855
Amount To Be Provided Debt Service	0	0	0	0	0	0	11,073,145
Total Assets	839,411	195,698	1,916,855	21,375	2,973,339	17,138,593	12,990,000
Liabilities							
Accounts Payable	6,673	0	0	0	6,673	0	0
Accrued Expenses	7,010	0	0	0	7,010	0	0
Revenue Bonds Payable-Long Term	0	0	0	0	0	0	12,990,000
Total Liabilities	13,683	0	0	0	13,683	0	12,990,000
Fund Equity & Other Credits							
Beginning Fund Balance	321,611	117,528	1,435,792	17,467	1,892,398	0	0
Investment In General Fixed Assets	0	0	0	0	0	17,138,593	0
Net Change in Fund Balance	504,118	78,170	481,063	3,908	1,067,259	0	0
Total Fund Equity & Other Credits	825,729	195,698	1,916,855	21,375	2,959,657	17,138,593	0
Total Liabilities & Fund Equity	839,411	195,698	1,916,855	21,375	2,973,339	17,138,593	12,990,000

See Notes to Unaudited Financial Statements

Trevesta Community Development District

Statement of Revenues and Expenditures

As of 03/31/2026

(In Whole Numbers)

	Year Ending 09/30/2026 <u>Annual Budget</u>	Through 03/31/2026 <u>YTD Budget</u>	Year To Date 03/31/2026 <u>YTD Actual</u>	<u>YTD Variance</u>
Revenues				
Interest Earnings				
Interest Earnings	0	0	365	365
Special Assessments				
Cost Share Contingency	12,526	12,526	0	(12,526)
Tax Roll	834,735	834,735	844,545	9,810
Total Revenues	<u>847,261</u>	<u>847,261</u>	<u>844,910</u>	<u>(2,351)</u>
Expenditures				
Legislative				
Supervisor Fees	7,000	3,500	2,400	1,100
Total Legislative	<u>7,000</u>	<u>3,500</u>	<u>2,400</u>	<u>1,100</u>
Financial & Administrative				
Accounting Services	21,271	10,635	10,636	0
Administrative Services	5,318	2,659	2,659	0
Arbitrage Rebate Calculation	1,000	0	0	0
Assessment Roll	5,908	5,908	5,908	0
Auditing Services	4,100	0	0	0
Disclosure Report	7,000	3,500	3,500	0
District Engineer	18,000	9,000	17,265	(8,265)
District Management	25,288	12,644	12,644	0
Dues, Licenses & Fees	375	375	175	200
Financial & Revenue Collections	4,254	2,127	2,127	0
Legal Advertising	1,600	800	0	800
Miscellaneous Fees	600	300	0	300
Public Officials Liability Insurance	3,752	3,752	3,252	500
Trustees Fees	14,000	9,334	8,750	583
Website Hosting, Maintenance, Backup & E	5,504	2,752	2,737	15
Total Financial & Administrative	<u>117,970</u>	<u>63,786</u>	<u>69,653</u>	<u>(5,867)</u>
Legal Counsel				
District Counsel	25,000	12,500	6,231	6,268
Total Legal Counsel	<u>25,000</u>	<u>12,500</u>	<u>6,231</u>	<u>6,268</u>
Electric Utility Services				
Utility - Street Lights	10,700	5,350	4,215	1,136
Utility Services	32,100	16,050	15,563	487
Total Electric Utility Services	<u>42,800</u>	<u>21,400</u>	<u>19,778</u>	<u>1,623</u>
Water-Sewer Combination Services				
Utility - Irrigation	58,000	29,000	23,276	5,724
Total Water-Sewer Combination Services	<u>58,000</u>	<u>29,000</u>	<u>23,276</u>	<u>5,724</u>
Stormwater Control				
Aquatic Maintenance	35,000	17,500	4,255	13,245
Fountain/Aeration Repairs & Maintenance	7,000	3,500	3,777	(277)
Lake/Pond Bank Maintenance & Repair	18,000	9,000	11,275	(2,275)

See Notes to Unaudited Financial Statements

Trevesta Community Development District

Statement of Revenues and Expenditures

As of 03/31/2026

(In Whole Numbers)

	Year Ending 09/30/2026	Through 03/31/2026	Year To Date 03/31/2026	
	Annual Budget	YTD Budget	YTD Actual	YTD Variance
Midge Fly Treatments	15,000	7,500	0	7,500
Wetland Monitoring & Maintenance	113,040	56,520	25,525	30,995
Total Stormwater Control	188,040	94,020	44,832	49,188
Other Physical Environment				
Entry & Walls Maintenance & Repair	5,000	2,500	0	2,500
Field Services	12,000	6,000	6,000	0
General Liability Insurance	4,663	4,663	3,922	741
Holiday Decorations	8,000	8,000	3,627	4,373
Landscape - Mulch	35,000	17,500	0	17,500
Landscape Maintenance	246,000	123,000	114,420	8,580
Landscape Replacement Plants, Shrubs, Tr	20,000	10,000	750	9,250
Property Insurance	13,388	13,388	8,969	4,419
Storm Damage/Restoration	5,000	2,500	0	2,500
Wildlife Management Services	14,400	7,200	9,121	(1,921)
Total Other Physical Environment	363,451	194,751	146,809	47,942
Contingency				
Miscellaneous Contingency	45,000	22,500	27,813	(5,313)
Total Contingency	45,000	22,500	27,813	(5,313)
Total Expenditures	847,261	441,457	340,792	100,665
Total Excess of Revenues Over(Under) Ex- penditures	0	405,804	504,118	98,314
Fund Balance, Beginning of Period	0	0	321,611	321,611
Total Fund Balance, End of Period	0	405,804	825,729	419,925

Trevesta Community Development District

Statement of Revenues and Expenditures

As of 03/31/2026

(In Whole Numbers)

	Year Ending 09/30/2026 <u>Annual Budget</u>	Through 03/31/2026 <u>YTD Budget</u>	Year To Date 03/31/2026 <u>YTD Actual</u>	<u>YTD Variance</u>
Revenues				
Interest Earnings				
Interest Earnings	0	0	2,412	2,412
Special Assessments				
Tax Roll	75,758	75,758	75,758	0
Total Revenues	<u>75,758</u>	<u>75,758</u>	<u>78,170</u>	<u>2,412</u>
Expenditures				
Contingency				
Capital Reserve	75,758	75,758	0	75,758
Total Contingency	<u>75,758</u>	<u>75,758</u>	<u>0</u>	<u>75,758</u>
Total Expenditures	<u>75,758</u>	<u>75,758</u>	<u>0</u>	<u>75,758</u>
Total Excess of Revenues Over(Under) Ex- penditures	<u>0</u>	<u>0</u>	<u>78,170</u>	<u>78,170</u>
Fund Balance, Beginning of Period	<u>0</u>	<u>0</u>	<u>117,528</u>	<u>117,528</u>
Total Fund Balance, End of Period	<u>0</u>	<u>0</u>	<u>195,698</u>	<u>195,698</u>

Trevesta Community Development District

Statement of Revenues and Expenditures

As of 03/31/2026

(In Whole Numbers)

	Year Ending 09/30/2026 <u>Annual Budget</u>	Through 03/31/2026 <u>YTD Budget</u>	Year To Date 03/31/2026 <u>YTD Actual</u>	<u>YTD Variance</u>
Revenues				
Interest Earnings				
Interest Earnings	0	0	10,312	10,312
Special Assessments				
Tax Roll	349,200	349,200	352,962	3,762
Total Revenues	<u>349,200</u>	<u>349,200</u>	<u>363,274</u>	<u>14,074</u>
Expenditures				
Debt Service				
Interest	249,200	249,200	118,328	130,872
Principal	100,000	100,000	105,000	(5,000)
Total Debt Service	<u>349,200</u>	<u>349,200</u>	<u>223,328</u>	<u>125,872</u>
Total Expenditures	<u>349,200</u>	<u>349,200</u>	<u>223,328</u>	<u>125,872</u>
Total Excess of Revenues Over(Under) Ex- penditures	<u>0</u>	<u>0</u>	<u>139,946</u>	<u>139,946</u>
Fund Balance, Beginning of Period	<u>0</u>	<u>0</u>	<u>637,517</u>	<u>637,517</u>
Total Fund Balance, End of Period	<u>0</u>	<u>0</u>	<u>777,463</u>	<u>777,463</u>

Trevesta Community Development District

Statement of Revenues and Expenditures

As of 03/31/2026

(In Whole Numbers)

	Year Ending 09/30/2026 <u>Annual Budget</u>	Through 03/31/2026 <u>YTD Budget</u>	Year To Date 03/31/2026 <u>YTD Actual</u>	<u>YTD Variance</u>
Revenues				
Interest Earnings				
Interest Earnings	0	0	7,800	7,800
Special Assessments				
Tax Roll	268,100	268,100	270,988	2,888
Total Revenues	<u>268,100</u>	<u>268,100</u>	<u>278,788</u>	<u>10,688</u>
Expenditures				
Debt Service				
Interest	198,100	198,100	94,994	103,106
Principal	70,000	70,000	75,000	(5,000)
Total Debt Service	<u>268,100</u>	<u>268,100</u>	<u>169,994</u>	<u>98,106</u>
Total Expenditures	<u>268,100</u>	<u>268,100</u>	<u>169,994</u>	<u>98,106</u>
Total Excess of Revenues Over(Under) Ex- penditures	<u>0</u>	<u>0</u>	<u>108,794</u>	<u>108,794</u>
Fund Balance, Beginning of Period	<u>0</u>	<u>0</u>	<u>482,505</u>	<u>482,505</u>
Total Fund Balance, End of Period	<u>0</u>	<u>0</u>	<u>591,299</u>	<u>591,299</u>

Trevesta Community Development District

Statement of Revenues and Expenditures

As of 03/31/2026

(In Whole Numbers)

	Year Ending 09/30/2026 <u>Annual Budget</u>	Through 03/31/2026 <u>YTD Budget</u>	Year To Date 03/31/2026 <u>YTD Actual</u>	<u>YTD Variance</u>
Revenues				
Interest Earnings				
Interest Earnings	0	0	5,560	5,560
Special Assessments				
Tax Roll	328,441	328,441	331,979	3,538
Total Revenues	<u>328,441</u>	<u>328,441</u>	<u>337,539</u>	<u>9,098</u>
Expenditures				
Debt Service				
Interest	208,441	208,441	101,694	106,747
Principal	120,000	120,000	0	120,000
Total Debt Service	<u>328,441</u>	<u>328,441</u>	<u>101,694</u>	<u>226,747</u>
Total Expenditures	<u>328,441</u>	<u>328,441</u>	<u>101,694</u>	<u>226,747</u>
Total Excess of Revenues Over(Under) Ex- penditures	<u>0</u>	<u>0</u>	<u>235,845</u>	<u>235,845</u>
Total Other Financing Sources(Uses)				
Interfund Transfer (Expense)				
Interfund Transfer	0	0	(3,522)	(3,522)
Total Other Financing Sources(Uses)	<u>0</u>	<u>0</u>	<u>(3,522)</u>	<u>(3,522)</u>
Fund Balance, Beginning of Period	<u>0</u>	<u>0</u>	<u>315,770</u>	<u>315,770</u>
Total Fund Balance, End of Period	<u>0</u>	<u>0</u>	<u>548,093</u>	<u>548,093</u>

Trevesta Community Development District

Statement of Revenues and Expenditures

As of 03/31/2026

(In Whole Numbers)

	Year Ending 09/30/2026 <u>Annual Budget</u>	Through 03/31/2026 <u>YTD Budget</u>	Year To Date 03/31/2026 <u>YTD Actual</u>	<u>YTD Variance</u>
Revenues				
Interest Earnings				
Interest Earnings	0	0	386	386
Total Revenues	<u>0</u>	<u>0</u>	<u>386</u>	<u>386</u>
Total Excess of Revenues Over(Under) Ex- penditures	<u>0</u>	<u>0</u>	<u>386</u>	<u>386</u>
Total Other Financing Sources(Uses)				
Interfund Transfer (Revenue)				
Interfund Transfer	0	0	3,522	3,522
Total Other Financing Sources(Uses)	<u>0</u>	<u>0</u>	<u>3,522</u>	<u>3,522</u>
Fund Balance, Beginning of Period	<u>0</u>	<u>0</u>	<u>17,467</u>	<u>17,467</u>
Total Fund Balance, End of Period	<u>0</u>	<u>0</u>	<u>21,375</u>	<u>21,375</u>

Trevesta CDD
Investment Summary
March 31, 2026

<u>Account</u>	<u>Investment</u>	<u>Balance as of</u> <u>March 31, 2026</u>
Valley National Bank	Governmental Checking	\$ 195,698
	Total Reserve Fund Investments	\$ 195,698
Regions Bank Series 2016 Reserve A-1	Fidelity Government Portfolio	\$ 261,379
Regions Bank Series 2016 Revenue A-1	Fidelity Government Portfolio	401,148
Regions Bank Series 2016 Interest A-1	Fidelity Government Portfolio	102,980
Regions Bank Series 2016 Prepayment A-1	Fidelity Government Portfolio	3,269
Regions Bank Series 2016 Principal A-1	Fidelity Government Portfolio	35
Regions Bank Series 2016 Redemption A-1	Fidelity Government Portfolio	2
Regions Bank Series 2018 Reserve	Fidelity Government Portfolio	209,532
Regions Bank Series 2018 Revenue	Fidelity Government Portfolio	372,973
Regions Bank Series 2018 Interest	Fidelity Government Portfolio	43
Regions Bank Series 2018 Prepayment	Fidelity Government Portfolio	1,800
Regions Bank Series 2018 Sinking Fund	Fidelity Government Portfolio	259
Regions Bank Series 2018 Redemption	Fidelity Government Portfolio	51
Regions Bank Series 2020 Reserve	Fidelity Government Portfolio	167,363
Regions Bank Series 2020 Revenue	Fidelity Government Portfolio	372,288
Regions Bank Series 2020 Interest	Fidelity Government Portfolio	13
Regions Bank Series 2020 Sinking Fund	Fidelity Government Portfolio	244
Regions Bank Series 2020 Principal	Fidelity Government Portfolio	49
	Total Debt Service Fund Investments	\$ 1,893,428
Regions Bank 2020 Construction	Fidelity Government Portfolio	\$ 21,375
	Total Capital Projects Fund Investments	\$ 21,375

FirstService Financial, an affiliate by ownership to your management company Rizzetta & Company, provides banking solutions exclusively to clients of Rizzetta & Company. FirstService Financial receives a monthly administration fee from partner financial institutions for our assistance with the development, placement, service, and maintenance of our banking programs without impacting the interest our clients earn on their funds. The monthly administration fee varies as it is negotiated with each participating financial institution.

**Trevesta Community Development District
Summary A/R Ledger
From 03/01/2026 to 03/31/2026**

Fund_ID	Fund Name	Customer	Invoice Number	AR Account	Date	Balance Due
241, 2274						
241-001	241 General Fund	Manatee County Tax Collector	AR00002925	12110	10/01/2025	22,553.38
241-001	241 General Fund	TBR Trevesta Place Owner, LLC	AR00003047	11510	10/01/2024	12,526.00
Sum for 241, 2274						35,079.38
241, 2275						
241-200	241 Debt Service Fund S2016	Manatee County Tax Collector	AR00002925	12110	10/01/2025	8,649.86
Sum for 241, 2275						8,649.86
241, 2276						
241-201	241 Debt Service Fund S2018	Manatee County Tax Collector	AR00002925	12110	10/01/2025	6,640.97
Sum for 241, 2276						6,640.97
241, 2277						
241-202	241 Debt Service Fund S2020	Manatee County Tax Collector	AR00002925	12110	10/01/2025	8,135.65
Sum for 241, 2277						8,135.65
Sum for 241						58,505.86
Sum Total						58,505.86

See Notes to Unaudited Financial Statements

**Trevesta Community Development District
Summary A/P Ledger
From 03/01/2026 to 03/31/2026**

Fund Name	GL posting date	Vendor name	Document number	Description	Balance Due
241, 2274					
241 General Fund	03/26/2026	Bloomings Landscape & Turf Management, Inc.	2026-00557	Water trailer 03/26	1,050.00
241 General Fund	03/17/2026	Kilinski Van Wyk, PLLC	14539	Legal Services 02/26	2,626.35
241 General Fund	03/17/2026	Peace River Electric Cooperative, Inc.	160096008-031726	6234 Kevesta Ave 02/26	65.20
241 General Fund	03/17/2026	Peace River Electric Cooperative, Inc.	160096002-031726	6810 Trevesta PL 02/26	1,052.17
241 General Fund	03/17/2026	Peace River Electric Cooperative, Inc.	160096001-031726	6204 Buffalo Road 02/26	40.47
241 General Fund	03/17/2026	Peace River Electric Cooperative, Inc.	160096006-031726	6405 Trevesta Place 02/26	39.50
241 General Fund	03/17/2026	Peace River Electric Cooperative, Inc.	160096004-031726	6581 Devesta Loop 02/26	158.26
241 General Fund	03/17/2026	Peace River Electric Cooperative, Inc.	160096003-031726	6810 Trevesta PL 02/26	597.07
241 General Fund	03/17/2026	Peace River Electric Cooperative, Inc.	160096005-031726	6727 Devesta Loop 02/26	290.04
241 General Fund	03/17/2026	Peace River Electric Cooperative, Inc.	160096007-031726	6227 Kevesta AVE 02/26	64.72
241 General Fund	08/01/2025	Rizzetta & Company, Inc.	RET0000001815	Landscape Consulting Serices over Charges 06/25	(900.00)
241 General Fund	03/17/2026	Sitex Aquatics, LLC	10870-b	Fountain Repairs 03/26	185.00
241 General Fund	03/12/2026	Stantec Consulting Services, Inc.	2542860	Engineering Services 02/26	1,404.00
Sum for 241, 2274					6,672.78
Sum for 241					6,672.78
Sum Total					6,672.78

Trevesta Community Development District
Notes to Unaudited Financial Statements
March 31, 2026

Balance Sheet

1. Trust statement activity has been recorded through 03/31/2026.
2. See EMMA (Electronic Municipal Market Access) at <https://emma.msrb.org> for Municipal Disclosures and Market Data.
3. For presentation purposes, the Reserves are shown in a separate fund titled Reserve Fund.

Summary A/R Ledger-Payment Terms

4. Payment terms for landowner assessments are (a) defined in the FY25-26 Assessment Resolution adopted by the Board of Supervisors, (b) pursuant to Florida Statutes, Chapter 197 for assessments levied via the county tax roll.



Rizzetta & Company

Trevesta Community Development District

**Financial Statements
(Unaudited)**

April 30, 2026

Prepared by: Rizzetta & Company, Inc.

trevestacdd.org
rizzetta.com

Trevesta Community Development District

Balance Sheet

As of 04/30/2026

(In Whole Numbers)

	General Fund	Reserve Fund	Debt Service Fund	Capital Project Fund	Total Gvmnt Fund	Fixed Assets Group	Long-Term Debt
Assets							
Cash In Bank	783,869	0	12,595	0	796,464	0	0
Investments	0	196,221	1,899,100	21,440	2,116,761	0	0
Accounts Receivable	22,955	0	10,832	0	33,786	0	0
Refundable Deposits	3,710	0	0	0	3,710	0	0
Fixed Assets	0	0	0	0	0	17,138,593	0
Amount Available in Debt Service	0	0	0	0	0	0	1,922,527
Amount To Be Provided Debt Service	0	0	0	0	0	0	11,067,473
Total Assets	810,534	196,221	1,922,527	21,440	2,950,721	17,138,593	12,990,000
Liabilities							
Accounts Payable	22,899	0	0	0	22,899	0	0
Accrued Expenses	3,250	0	0	0	3,250	0	0
Revenue Bonds Payable-Long Term	0	0	0	0	0	0	12,990,000
Total Liabilities	26,149	0	0	0	26,149	0	12,990,000
Fund Equity & Other Credits							
Beginning Fund Balance	321,611	117,528	1,435,792	17,467	1,892,398	0	0
Investment In General Fixed Assets	0	0	0	0	0	17,138,593	0
Net Change in Fund Balance	462,774	78,693	486,735	3,973	1,032,174	0	0
Total Fund Equity & Other Credits	784,385	196,221	1,922,527	21,440	2,924,572	17,138,593	0
Total Liabilities & Fund Equity	810,534	196,221	1,922,527	21,440	2,950,721	17,138,593	12,990,000

See Notes to Unaudited Financial Statements

Trevesta Community Development District

Statement of Revenues and Expenditures

As of 04/30/2026

(In Whole Numbers)

	Year Ending 09/30/2026 <u>Annual Budget</u>	Through 04/30/2026 <u>YTD Budget</u>	Year To Date 04/30/2026 <u>YTD Actual</u>	<u>YTD Variance</u>
Revenues				
Interest Earnings				
Interest Earnings	0	0	429	429
Special Assessments				
Cost Share Contingency	12,526	12,526	0	(12,526)
Tax Roll	834,735	834,735	844,545	9,810
Total Revenues	<u>847,261</u>	<u>847,261</u>	<u>844,974</u>	<u>(2,287)</u>
Expenditures				
Legislative				
Supervisor Fees	7,000	4,083	3,400	684
Total Legislative	<u>7,000</u>	<u>4,083</u>	<u>3,400</u>	<u>684</u>
Financial & Administrative				
Accounting Services	21,271	12,408	12,408	0
Administrative Services	5,318	3,103	3,102	0
Arbitrage Rebate Calculation	1,000	0	0	0
Assessment Roll	5,908	5,908	5,908	0
Auditing Services	4,100	0	0	0
Disclosure Report	7,000	4,083	4,083	0
District Engineer	18,000	10,500	16,137	(5,637)
District Management	25,288	14,751	14,751	0
Dues, Licenses & Fees	375	375	175	200
Financial & Revenue Collections	4,254	2,482	2,482	0
Legal Advertising	1,600	933	0	933
Miscellaneous Fees	600	350	0	350
Public Officials Liability Insurance	3,752	3,752	3,252	500
Trustees Fees	14,000	14,000	8,750	5,250
Website Hosting, Maintenance, Backup & E	5,504	3,211	2,937	273
Total Financial & Administrative	<u>117,970</u>	<u>75,856</u>	<u>73,985</u>	<u>1,869</u>
Legal Counsel				
District Counsel	25,000	14,583	7,664	6,920
Total Legal Counsel	<u>25,000</u>	<u>14,583</u>	<u>7,664</u>	<u>6,920</u>
Electric Utility Services				
Utility - Street Lights	10,700	6,242	4,810	1,432
Utility Services	32,100	18,725	15,464	3,261
Total Electric Utility Services	<u>42,800</u>	<u>24,967</u>	<u>20,274</u>	<u>4,693</u>
Water-Sewer Combination Services				
Utility - Irrigation	58,000	33,833	32,586	1,247
Total Water-Sewer Combination Services	<u>58,000</u>	<u>33,833</u>	<u>32,586</u>	<u>1,247</u>
Stormwater Control				
Aquatic Maintenance	35,000	20,417	5,255	15,161
Fountain/Aeration Repairs & Maintenance	7,000	4,083	4,477	(393)
Lake/Pond Bank Maintenance & Repair	18,000	10,500	13,530	(3,030)

See Notes to Unaudited Financial Statements

Trevesta Community Development District

Statement of Revenues and Expenditures

As of 04/30/2026

(In Whole Numbers)

	Year Ending 09/30/2026	Through 04/30/2026	Year To Date 04/30/2026	
	Annual Budget	YTD Budget	YTD Actual	YTD Variance
Midge Fly Treatments	15,000	8,750	0	8,750
Wetland Monitoring & Maintenance	113,040	65,940	25,525	40,415
Total Stormwater Control	188,040	109,690	48,787	60,903
Other Physical Environment				
Entry & Walls Maintenance & Repair	5,000	2,917	0	2,916
Field Services	12,000	7,000	7,000	0
General Liability Insurance	4,663	4,663	3,922	741
Holiday Decorations	8,000	8,000	3,628	4,373
Landscape - Mulch	35,000	20,416	0	20,417
Landscape Maintenance	246,000	143,500	133,080	10,420
Landscape Replacement Plants, Shrubs, Tr	20,000	11,667	750	10,917
Property Insurance	13,388	13,388	8,969	4,419
Storm Damage/Restoration	5,000	2,917	0	2,916
Wildlife Management Services	14,400	8,400	9,120	(721)
Total Other Physical Environment	363,451	222,868	166,469	56,398
Contingency				
Miscellaneous Contingency	45,000	26,250	29,035	(2,784)
Total Contingency	45,000	26,250	29,035	(2,784)
Total Expenditures	847,261	512,130	382,200	129,930
Total Excess of Revenues Over(Under) Ex- penditures	0	335,131	462,774	127,643
Fund Balance, Beginning of Period	0	0	321,611	321,610
Total Fund Balance, End of Period	0	335,131	784,385	449,253

Trevesta Community Development District

Statement of Revenues and Expenditures

As of 04/30/2026

(In Whole Numbers)

	Year Ending 09/30/2026 <u>Annual Budget</u>	Through 04/30/2026 <u>YTD Budget</u>	Year To Date 04/30/2026 <u>YTD Actual</u>	<u>YTD Variance</u>
Revenues				
Interest Earnings				
Interest Earnings	0	0	2,935	2,935
Special Assessments				
Tax Roll	75,758	75,758	75,758	0
Total Revenues	<u>75,758</u>	<u>75,758</u>	<u>78,693</u>	<u>2,935</u>
Expenditures				
Contingency				
Capital Reserve	75,758	75,758	0	75,758
Total Contingency	<u>75,758</u>	<u>75,758</u>	<u>0</u>	<u>75,758</u>
Total Expenditures	<u>75,758</u>	<u>75,758</u>	<u>0</u>	<u>75,758</u>
Total Excess of Revenues Over(Under) Ex-	<u>0</u>	<u>0</u>	<u>78,693</u>	<u>78,693</u>
penditures				
Fund Balance, Beginning of Period	<u>0</u>	<u>0</u>	<u>117,528</u>	<u>117,528</u>
Total Fund Balance, End of Period	<u>0</u>	<u>0</u>	<u>196,221</u>	<u>196,221</u>

Trevesta Community Development District

Statement of Revenues and Expenditures

As of 04/30/2026

(In Whole Numbers)

	Year Ending 09/30/2026 <u>Annual Budget</u>	Through 04/30/2026 <u>YTD Budget</u>	Year To Date 04/30/2026 <u>YTD Actual</u>	<u>YTD Variance</u>
Revenues				
Interest Earnings				
Interest Earnings	0	0	12,616	12,616
Special Assessments				
Tax Roll	349,200	349,200	352,962	3,762
Total Revenues	<u>349,200</u>	<u>349,200</u>	<u>365,578</u>	<u>16,378</u>
Expenditures				
Debt Service				
Interest	249,200	249,200	118,329	130,871
Principal	100,000	100,000	105,000	(5,000)
Total Debt Service	<u>349,200</u>	<u>349,200</u>	<u>223,329</u>	<u>125,871</u>
Total Expenditures	<u>349,200</u>	<u>349,200</u>	<u>223,329</u>	<u>125,871</u>
Total Excess of Revenues Over(Under) Ex- penditures	<u>0</u>	<u>0</u>	<u>142,249</u>	<u>142,249</u>
Fund Balance, Beginning of Period	<u>0</u>	<u>0</u>	<u>637,517</u>	<u>637,517</u>
Total Fund Balance, End of Period	<u>0</u>	<u>0</u>	<u>779,766</u>	<u>779,766</u>

Trevesta Community Development District

Statement of Revenues and Expenditures

As of 04/30/2026

(In Whole Numbers)

	Year Ending 09/30/2026 <u>Annual Budget</u>	Through 04/30/2026 <u>YTD Budget</u>	Year To Date 04/30/2026 <u>YTD Actual</u>	<u>YTD Variance</u>
Revenues				
Interest Earnings				
Interest Earnings	0	0	9,552	9,552
Special Assessments				
Tax Roll	268,100	268,100	270,987	2,888
Total Revenues	<u>268,100</u>	<u>268,100</u>	<u>280,539</u>	<u>12,440</u>
Expenditures				
Debt Service				
Interest	198,100	198,100	94,994	103,105
Principal	70,000	70,000	75,000	(5,000)
Total Debt Service	<u>268,100</u>	<u>268,100</u>	<u>169,994</u>	<u>98,105</u>
Total Expenditures	<u>268,100</u>	<u>268,100</u>	<u>169,994</u>	<u>98,105</u>
Total Excess of Revenues Over(Under) Ex- penditures	<u>0</u>	<u>0</u>	<u>110,545</u>	<u>110,545</u>
Fund Balance, Beginning of Period	<u>0</u>	<u>0</u>	<u>482,506</u>	<u>482,506</u>
Total Fund Balance, End of Period	<u>0</u>	<u>0</u>	<u>593,051</u>	<u>593,051</u>

Trevesta Community Development District

Statement of Revenues and Expenditures

As of 04/30/2026

(In Whole Numbers)

	Year Ending 09/30/2026 <u>Annual Budget</u>	Through 04/30/2026 <u>YTD Budget</u>	Year To Date 04/30/2026 <u>YTD Actual</u>	<u>YTD Variance</u>
Revenues				
Interest Earnings				
Interest Earnings	0	0	7,177	7,177
Special Assessments				
Tax Roll	328,441	328,441	331,979	3,538
Total Revenues	<u>328,441</u>	<u>328,441</u>	<u>339,156</u>	<u>10,715</u>
Expenditures				
Debt Service				
Interest	208,441	208,441	101,694	106,747
Principal	120,000	120,000	0	120,000
Total Debt Service	<u>328,441</u>	<u>328,441</u>	<u>101,694</u>	<u>226,747</u>
Total Expenditures	<u>328,441</u>	<u>328,441</u>	<u>101,694</u>	<u>226,747</u>
Total Excess of Revenues Over(Under) Ex- penditures	<u>0</u>	<u>0</u>	<u>237,462</u>	<u>237,462</u>
Total Other Financing Sources(Uses)				
Interfund Transfer (Expense)				
Interfund Transfer	0	0	(3,522)	(3,522)
Total Other Financing Sources(Uses)	<u>0</u>	<u>0</u>	<u>(3,522)</u>	<u>(3,522)</u>
Fund Balance, Beginning of Period	<u>0</u>	<u>0</u>	<u>315,770</u>	<u>315,770</u>
Total Fund Balance, End of Period	<u>0</u>	<u>0</u>	<u>549,710</u>	<u>549,710</u>

Trevesta Community Development District

Statement of Revenues and Expenditures

As of 04/30/2026

(In Whole Numbers)

	Year Ending 09/30/2026 <u>Annual Budget</u>	Through 04/30/2026 <u>YTD Budget</u>	Year To Date 04/30/2026 <u>YTD Actual</u>	<u>YTD Variance</u>
Revenues				
Interest Earnings				
Interest Earnings	0	0	450	450
Total Revenues	<u>0</u>	<u>0</u>	<u>450</u>	<u>450</u>
Total Excess of Revenues Over(Under) Ex- penditures	<u>0</u>	<u>0</u>	<u>450</u>	<u>450</u>
Total Other Financing Sources(Uses)				
Interfund Transfer (Revenue)				
Interfund Transfer	0	0	3,522	3,522
Total Other Financing Sources(Uses)	<u>0</u>	<u>0</u>	<u>3,522</u>	<u>3,522</u>
Fund Balance, Beginning of Period	<u>0</u>	<u>0</u>	<u>17,468</u>	<u>17,468</u>
Total Fund Balance, End of Period	<u>0</u>	<u>0</u>	<u>21,440</u>	<u>21,440</u>

Trevesta CDD
Investment Summary
April 30, 2026

<u>Account</u>	<u>Investment</u>	<u>Balance as of</u> <u>April 30, 2026</u>
Valley National Bank	Governmental Checking	\$ 196,221
Total Reserve Fund Investments		\$ 196,221
Regions Bank Series 2016 Reserve A-1	Fidelity Government Portfolio	\$ 262,163
Regions Bank Series 2016 Revenue A-1	Fidelity Government Portfolio	389,624
Regions Bank Series 2016 Interest A-1	Fidelity Government Portfolio	103,289
Regions Bank Series 2016 Prepayment A-1	Fidelity Government Portfolio	16,002
Regions Bank Series 2016 Principal A-1	Fidelity Government Portfolio	35
Regions Bank Series 2016 Redemption A-1	Fidelity Government Portfolio	2
Regions Bank Series 2018 Reserve	Fidelity Government Portfolio	210,161
Regions Bank Series 2018 Revenue	Fidelity Government Portfolio	280,877
Regions Bank Series 2018 Interest	Fidelity Government Portfolio	93,256
Regions Bank Series 2018 Prepayment	Fidelity Government Portfolio	1,805
Regions Bank Series 2018 Sinking Fund	Fidelity Government Portfolio	260
Regions Bank Series 2018 Redemption	Fidelity Government Portfolio	51
Regions Bank Series 2020 Reserve	Fidelity Government Portfolio	167,866
Regions Bank Series 2020 Revenue	Fidelity Government Portfolio	146,708
Regions Bank Series 2020 Interest	Fidelity Government Portfolio	101,707
Regions Bank Series 2020 Sinking Fund	Fidelity Government Portfolio	125,245
Regions Bank Series 2020 Principal	Fidelity Government Portfolio	49
Total Debt Service Fund Investments		\$ 1,899,100
Regions Bank 2020 Construction	Fidelity Government Portfolio	\$ 21,440
Total Capital Projects Fund Investments		\$ 21,440

FirstService Financial, an affiliate by ownership to your management company Rizzetta & Company, provides banking solutions exclusively to clients of Rizzetta & Company. FirstService Financial receives a monthly administration fee from partner financial institutions for our assistance with the development, placement, service, and maintenance of our banking programs without impacting the interest our clients earn on their funds. The monthly administration fee varies as it is negotiated with each participating financial institution.

**Trevesta Community Development District
Summary A/R Ledger
From 04/01/2026 to 04/30/2026**

Fund_ID	Fund Name	Customer	Invoice Number	AR Account	Date	Balance Due
241, 2274						
241-001	241 General Fund	Manatee County Tax Collector	AR00002925	12110	10/01/2025	10,428.06
241-001	241 General Fund	TBR Trevesta Place Owner, LLC	AR00003047	11510	10/01/2024	12,526.00
Sum for 241, 2274						22,954.06
241, 2275						
241-200	241 Debt Service Fund S2016	Manatee County Tax Collector	AR00002925	12110	10/01/2025	3,999.46
Sum for 241, 2275						3,999.46
241, 2276						
241-201	241 Debt Service Fund S2018	Manatee County Tax Collector	AR00002925	12110	10/01/2025	3,070.61
Sum for 241, 2276						3,070.61
241, 2277						
241-202	241 Debt Service Fund S2020	Manatee County Tax Collector	AR00002925	12110	10/01/2025	3,761.71
Sum for 241, 2277						3,761.71
Sum for 241						33,785.84
Sum Total						33,785.84

See Notes to Unaudited Financial Statements

**Trevesta Community Development District
Summary A/P Ledger
From 04/01/2026 to 04/30/2026**

Fund Name	GL posting date	Vendor name	Document number	Description	Balance Due
241, 2274					
241 General Fund	04/27/2026	Bloomings Landscape & Turf Management, Inc.	2026-00787	Water trailer 04/26	1,750.00
241 General Fund	04/01/2026	Bloomings Landscape & Turf Management, Inc.	2026-00655	Monthly Grounds Maintenance 04/26	18,660.00
241 General Fund	04/12/2026	Kilinski Van Wyk, PLLC	14785	Legal Services 03/26	1,432.00
241 General Fund	04/27/2026	Peace River Electric Cooperative, Inc.	160096004-041626	6581 Devesta Loop 03/26	111.24
241 General Fund	04/27/2026	Peace River Electric Cooperative, Inc.	160096001-041626	6204 Buffalo Road 03/26	40.47
241 General Fund	04/16/2026	Peace River Electric Cooperative, Inc.	160096007-041626	6227 Kevesta AVE 03/26	64.48
241 General Fund	04/27/2026	Peace River Electric Cooperative, Inc.	160096008-041626	6234 Kevesta Ave 03/26	65.32
241 General Fund	04/27/2026	Peace River Electric Cooperative, Inc.	160096006-041626	6405 Trevesta Place 03/26	39.88
241 General Fund	04/27/2026	Peace River Electric Cooperative, Inc.	160096005-041626	6727 Devesta Loop 03/26	224.14
241 General Fund	04/27/2026	Peace River Electric Cooperative, Inc.	160096003-041626	6810 Trevesta PL 03/26	596.25
241 General Fund	04/27/2026	Peace River Electric Cooperative, Inc.	160096002-041626	6810 Trevesta PL 03/26	815.01
241 General Fund	08/01/2025	Rizzetta & Company, Inc.	RET0000001815	Landscape Consulting Serices over Charges 06/25	(900.00)
Sum for 241, 2274					22,898.79
Sum for 241					22,898.79
Sum Total					22,898.79

Trevesta Community Development District
Notes to Unaudited Financial Statements
May 30, 2026

Balance Sheet

1. Trust statement activity has been recorded through 05/30/2026.
2. See EMMA (Electronic Municipal Market Access) at <https://emma.msrb.org> for Municipal Disclosures and Market Data.
3. For presentation purposes, the Reserves are shown in a separate fund titled Reserve Fund.

Summary A/R Ledger-Payment Terms

4. Payment terms for landowner assessments are (a) defined in the FY25-26 Assessment Resolution adopted by the Board of Supervisors, (b) pursuant to Florida Statutes, Chapter 197 for assessments levied via the county tax roll.

Tab 15

TREVESTA COMMUNITY DEVELOPMENT DISTRICT

District Office · Riverview · Florida · 813-994-1001

Mailing Address – 3434 Colwell Avenue, Suite 200, Tampa, Florida 33614

Operation and Maintenance Expenditures

March 2026

For Board Approval

Attached please find the check register listing the Operation and Maintenance expenditures paid from March 1, 2026 through March 31, 2026. This does not include expenditures previously approved by the Board.

The total items being presented: **\$61,723.77**

Approval of Expenditures:

_____ Chairperson

_____ Vice Chairperson

_____ Assistant Secretary

Trevesta Community Development District

Paid Operation & Maintenance Expenditures

March 1, 2026 Through March 31, 2026

<u>Vendor Name</u>	<u>Check Number</u>	<u>Invoice Number</u>	<u>Invoice Description</u>	<u>Invoice Amount</u>
Bloomings Landscape & Turf Management, Inc.	100564	2026-00258	Monthly Grounds Maintenance 02/26	\$ 18,660.00
Bloomings Landscape & Turf Management, Inc.	100564	2026-00451	Monthly Grounds Maintenance 03/26	\$ 18,660.00
Bloomings Landscape & Turf Management, Inc.	100566	2026-00495	Water trailer 03/26	\$ 1,050.00
FWU Environmental Services	100565	90184000	Water Service 03/26	\$ 4,655.20
Kilinski Van Wyk, PLLC	100567	14281	Legal Services 01/26	\$ 672.00
Peace River Electric Cooperative, Inc.	20260310-8	160096001-021726	ACH 6204 Buffalo Road 01/26	\$ 40.84
Peace River Electric Cooperative, Inc.	20260310-7	160096002-021726	ACH 6810 Trevesta PL 01/26	\$ 1,038.99
Peace River Electric Cooperative, Inc.	20260310-6	160096003-021726	ACH 6810 Trevesta PL 01/26	\$ 600.59
Peace River Electric Cooperative, Inc.	20260310-5	160096004-021726	ACH 6581 Devesta Loop 01/26	\$ 161.29
Peace River Electric Cooperative, Inc.	20260310-4	160096005-021726	ACH 6727 Devesta Loop 01/26	\$ 297.59
Peace River Electric Cooperative, Inc.	20260310-3	160096006-021726	ACH 6405 Trevesta Place 01/26	\$ 40.47
Peace River Electric Cooperative, Inc.	20260310-2	160096007-021726	ACH 6227 Kevesta AVE 01/26	\$ 64.59
Peace River Electric Cooperative, Inc.	20260310-1	160096008-021726	ACH 6234 Kevesta Ave 01/26	\$ 66.30
Regions Bank Corporate Trust	100568	127983	Special Assessment Bonds Series 2018 Area 1	\$ 3,500.00

Trevesta Community Development District

Paid Operation & Maintenance Expenditures

March 1, 2026 Through March 31, 2026

<u>Vendor Name</u>	<u>Check Number</u>	<u>Invoice Number</u>	<u>Invoice Description</u>	<u>Invoice Amount</u>
Regions Bank Corporate Trust	100570	129538	Special Assessment Bonds Series 2020 Area 2 02/26	\$ 3,500.00
Rizzetta & Company, Inc.	100563	INV0000107442	Accounting Services 03/26	\$ 6,460.91
Sitex Aquatics, LLC	100569	10853-b	Monthly Lake Maintenance 03/26	\$ <u>2,255.00</u>
Report Total				\$ <u>61,723.77</u>



Invoice

5824 Bee Ridge Road #165, Sarasota, FL 34233

Date **Invoice #**
 2/1/2026 2026-00258

Bill To:

Trevesta CDD
c/o Rizzetta & Company, Inc.
2700 S. Faulkenberg Rd
Riverview, FL 33578

Description	Qty	Rate	Amount
Month of February Monthly Grounds Maintenance Fee		18,660.00	18,660.00

Terms

Net 45

PAYMENT ACCEPTED: BANK TRANSFER (ACH) & CHECK
Make check payable to:
Bloomings Landscape & Turf Management, Inc.
Please include invoice number on your check.
Thank You For Your Business.

Total	\$18,660.00
Payments/Credits	\$0.00
Balance Due	\$18,660.00

Phone #

Fax #

E-mail

Web Site

(941) 927-9765

amy@bloomingslandscape.com

www.bloomingslandscape.com



Invoice

5824 Bee Ridge Road #165, Sarasota, FL 34233

Date **Invoice #**
 3/1/2026 2026-00451

Bill To:

Trevesta CDD
c/o Rizzetta & Company, Inc.
2700 S. Faulkenberg Rd
Riverview, FL 33578

		Terms	Net 45
Description	Qty	Rate	Amount
Month of March Monthly Grounds Maintenance Fee		18,660.00	18,660.00

PAYMENT ACCEPTED: BANK TRANSFER (ACH) & CHECK
 Make check payable to:
Bloomings Landscape & Turf Management, Inc.
 Please include invoice number on your check.
 Thank You For Your Business.

Total	\$18,660.00
Payments/Credits	\$0.00
Balance Due	\$18,660.00

Phone #	Fax #	E-mail	Web Site
(941) 927-9765		amy@bloomingslandscape.com	www.bloomingslandscape.com



Invoice

5824 Bee Ridge Road #165, Sarasota, FL 34233

Date **Invoice #**
 3/10/2026 2026-00495

Bill To:

Trevesta CDD
c/o Rizzetta & Company, Inc.
2700 S. Faulkenberg Rd
Riverview, FL 33578

		Terms	Due on receipt
Description	Qty	Rate	Amount
Water Trailer Watered Viburnum hedge east and west side of Buffalo Rd. Water Trevesta Place turf and hedges to include the pocket park inside Trevesta Gate.	6	175.00	1,050.00

PAYMENT ACCEPTED: BANK TRANSFER (ACH) & CREDIT CARD.
 Please note that there is a 3% Processing Fee on Credit Card Payments.

Thank You For Your Business.

Total	\$1,050.00
Payments/Credits	\$0.00
Balance Due	\$1,050.00

Phone #	Fax #	E-mail	Web Site
(941) 927-9765		amy@bloomingslandscape.com	www.bloomingslandscape.com

INVOICE



Florida Water Utilities

Environmental Services

A SouthWest Water Company

Invoice # : 90184000

Invoice Date : 03-04-2026

Remit Payment To:

FWU Environmental Services

P.O. Box 290910

Columbia, SC 29229

Phone: (803) 995-5070

Email: meagan.douglas@nexuswg.com

www.nexuswg.com

Bill-To:

Trevesta CDD

Rizzetta Mangement Services

9428 CAMDEN FIELD PKWY

RIVERVIEW, FL 33578-0519

Payment Terms	Due Date	Representative	District
Payable upon receipt	03-04-2026		Trevesta

Service Performed	Quantity	Rate	Amount
Phase 1A Common Area	5.300	264.50	1,401.85
Phase 1B Common Area	5.300	264.50	1,401.85
Phase 2 Common Area	7	264.50	1,851.50

Subtotal	4,655.20
Sales Tax	0.00
Total	4,655.20



KILINSKI | VAN WYK

Kilinski | Van Wyk PLLC

P.O. Box 6386
Tallahassee, Florida 32314
United States

Trevesta CDD
2700 S. Falkenburg Rd. Suite 2745
Riverview, Florida 33578

INVOICE

Invoice # 14281
Date: 02/19/2026
Due On: 03/21/2026

Statement of Account

Outstanding Balance	New Charges	Payments Received	Total Amount Outstanding
(\$1,221.50	+ \$672.00) - (\$0.00) = \$1,893.50

TRVCDD-01

Trevesta CDD - General

Type	Attorney	Date	Notes	Quantity	Rate	Total
Service	SH	01/05/2026	Monitor and report on bills affecting special districts.	0.20	\$300.00	\$60.00
Service	SD	01/06/2026	Receive "EFDMS Submission Received" email and update district files regarding same.	0.10	\$190.00	\$19.00
Service	MH	01/06/2026	Confer with District Manager regarding request for conveyance of Tract F3. Initiate review of documents related to same.	0.20	\$375.00	\$75.00
Service	MH	01/07/2026	Advise regarding F3 conveyance and required documentation for same.	0.20	\$375.00	\$75.00
Service	MH	01/14/2026	Confer with counsel for VK Trevesta LLC regarding conveyance of Tract F-3.	0.20	\$375.00	\$75.00
Service	MH	01/16/2026	Advise and confer with Supervisor Hoyt regarding status of F3 conveyance.	0.20	\$375.00	\$75.00
Service	MH	01/26/2026	Initiate review of Tract F3 conveyance	0.40	\$375.00	\$150.00

documents and property report;
confer with Supervisor Hoyt regarding
the same.

Service	PC	01/28/2026	Analysis of tentative agenda for February meeting of the Board of Supervisors.	0.10	\$300.00	\$30.00
Service	AH	01/28/2026	Confer with Bregg regarding agenda items.	0.20	\$190.00	\$38.00
Service	MH	01/30/2026	Confer with Supervisor Hoyt and advise regarding Tract F3 conveyance matters.	0.20	\$375.00	\$75.00
					Total	\$672.00

Please make all amounts payable to: Kilinski | Van Wyk PLLC

Please pay within 30 days.



Peace River Electric Cooperative, Inc.

TREVESTA CDD

Bill Date
Account #
Member #

02/17/2026
160096001
159427

Customer Care 800-282-3824 8am - 5pm M-F
Pay by Phone 855-937-1752
Outage 800-282-3824 24/7
Website www.preco.coop



TOTAL AMOUNT DUE

\$40.84

Bank Draft is scheduled for 03/10/2026

Monthly Energy Use

Kilowatt Hours

Previous Months

Current Month

Avg Temp

Temp

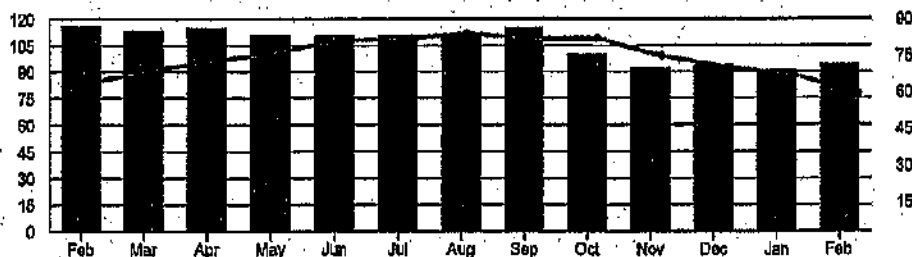

2025

2026

Detailed usage information is available on the SmarHub App or www.preco.coop

Monthly Energy Use Comparison

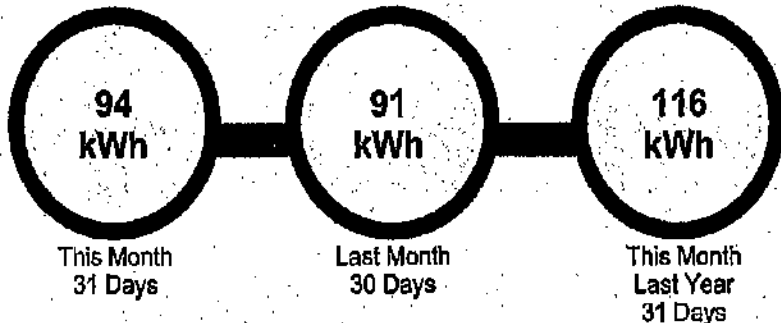

Your Average Daily Use

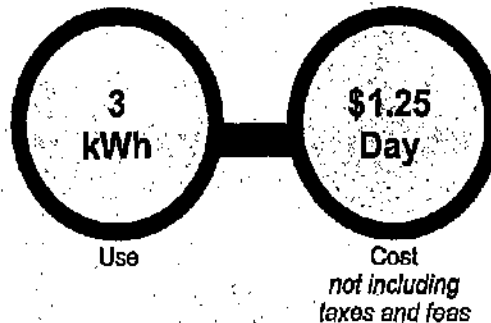

Please make check payable to PRECO in U.S. funds and return this portion with your payment.



Peace River Electric Cooperative, Inc.

PO Box 1310
210 Methery Road
Wauchula, Florida 33873
800.282.3824

Account #
Service Address

160096001
6204 BUFFALO RD

Bank Draft Amount \$40.84
is scheduled for 03/10/2026



PEACE RIVER ELECTRIC COOPERATIVE, INC.
PO BOX 1547
WAUCHULA FL 33873-1547

TREVESTA CDD
PO BOX 32414
CHARLOTTE NC 28232-2414



Account
160096001

Service Address
6204 BUFFALO RD

Service Description
175 TOWER SIGN

Board District
8

Meter #	Service Period		Readings		Meter Multiplier	kWh Usage	kW Reading
	From	To	Previous	Present			
34330156	01/09/2026	02/09/2026	18.112	18.206	1.0	94	0.126

Account Summary

Previous Balance
Payment(s) Made
Balance Forward
Current Charges
Total Amount Due

\$40.47
-\$40.47
\$0.00
\$40.84
\$40.84

Current Charges

Facilities Use Charge
Energy Charge
CPA
Property Tax Recovery Fee
Gross Receipts Tax
Total Current Charges

94 kWh @ 0.121
94 kWh @ -0.005

GS-S
\$28.00
\$11.37
-\$0.47
\$0.92
\$1.02
\$40.84

Bank Draft Amount

\$40.84



PRECO Offers



\$140,000 in

College Scholarships

Application deadline is February 29
Apply online at www.precocoop.com/community/scholarships









Now offering cash bill-pay service at participating retail stores. The barcode below can be scanned at the register, allowing you to make your monthly payment. There is a \$1.50 convenience fee to use this service. To find a location near you, visit pay.vanilladirect.com/pages/retailers



799366433650001102601600960017

By accepting or using this barcode to make a payment, you agree to the full terms and conditions, available at vanilladirect.com/pay/terms. After successful payment using this barcode, you may retrieve your full detailed e-receipt at vanilladirect.com/pay/e-receipt.

The majority of participating locations will accept cash payments up to a maximum amount of \$500.00.





Peace River Electric Cooperative, Inc.

TREVESTA CDD

Bill Date
Account #
Member #

02/17/2026
160096002
159427

Customer Care 800-282-3824 8am - 5pm M-F
Pay by Phone 855-937-1752
Outage 800-282-3824 24/7
Website www.precocoop



TOTAL AMOUNT DUE

\$1,038.99

Bank Draft is scheduled for 03/10/2026

Monthly Energy Use

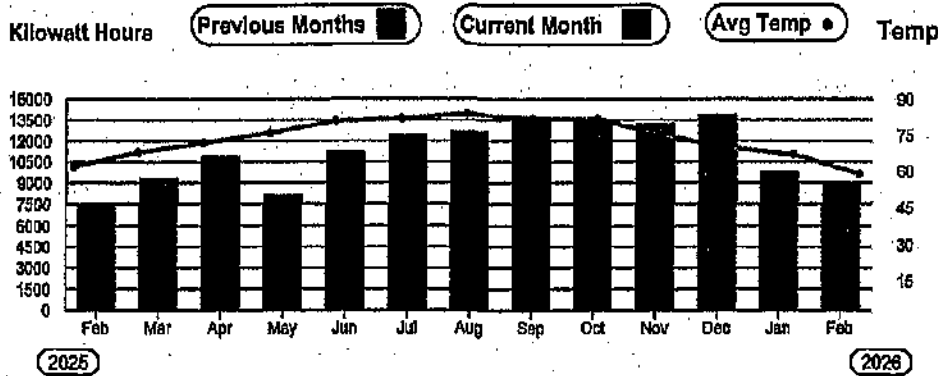

Detailed usage information is available on the SmartHub App or www.precocoop

Monthly Energy Use Comparison

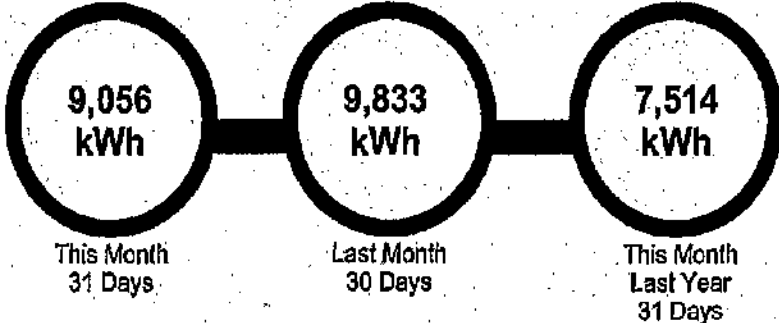

Your Average Daily Use

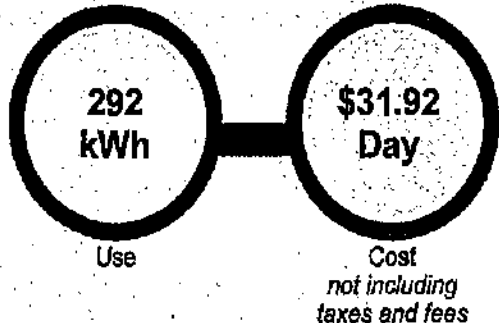

Please make check payable to PRECO in U.S. funds and return this portion with your payment.



Peace River Electric Cooperative, Inc.

PO Box 1310
210 Methery Road
Wauchula, Florida 33873
800.282.3824

Account #
Service Address

160096002
6810 TREVESTA PL

Bank Draft Amount \$1,038.99
is scheduled for 03/10/2026



TREVESTA CDD
PO BOX 32414
CHARLOTTE NC 28232-2414

PEACE RIVER ELECTRIC COOPERATIVE, INC.
PO BOX 1547
WAUCHULA FL 33873-1547



Account
180096002

Service Address
6810 TREVISTA PL

Service Description
ENTRANCE TOWER/MONUMENT SIGN

Board District
8

Meter #	Service Period		Readings		Meter Multiplier	kWh Usage	kW Reading
	From	To	Previous	Present			
34330124	01/09/2026	02/09/2026	903,758	912,814	1.0	9,056	19.04
Account Summary			Current Charges				GSD
Previous Balance			\$1,102.63	Facilities Use Charge		\$110.00	
Payment(s) Made			-\$1,102.63	Energy Charge	9,056 kWh @ 0.083	\$751.65	
Balance Forward			\$0.00	CPA	9,056 kWh @ -0.005	-\$45.28	
Current Charges			\$1,038.99	Billed Demand	20.000 kW @ 8.660	\$173.20	
Total Amount Due			\$1,038.99	Property Tax Recovery Fee		\$23.45	
				Gross Receipts Tax		\$25.97	
				Total Current Charges		\$1,038.99	
Bank Draft Amount						\$1,038.99	



PRECO Offers



\$140,000 in College Scholarships

Application deadline is February 28

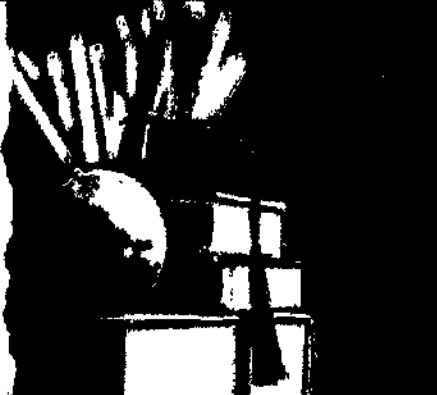
Apply online at www.preco.coop/community/scholarships









Now offering cash bill-pay service at participating retail stores. The barcode below can be scanned at the register, allowing you to make your monthly payment. There is a \$1.50 convenience fee to use this service. To find a location near you, visit pay.vanilladirect.com/pages/retailers



799366433650001102601600960025

By accepting or using this barcode to make a payment, you agree to the full terms and conditions, available at vanilladirect.com/pay/terms. After successful payment using this barcode, you may retrieve your full detailed e-receipt at vanilladirect.com/pay/receipt.

The majority of participating locations will accept cash payments up to a maximum amount of \$500.00.





Peace River Electric Cooperative, Inc.

TREVESTA CDD

Bill Date
Account #
Member #

02/17/2026
160096003
159427

Customer Care 800-282-3824 8am - 5pm M-F
Pay by Phone 855-837-1752
Outage 800-282-3824 24/7
Website www.precio.coop



**TOTAL
AMOUNT DUE**

\$600.59

Bank Draft is
scheduled for
03/10/2026

Monthly Energy Use

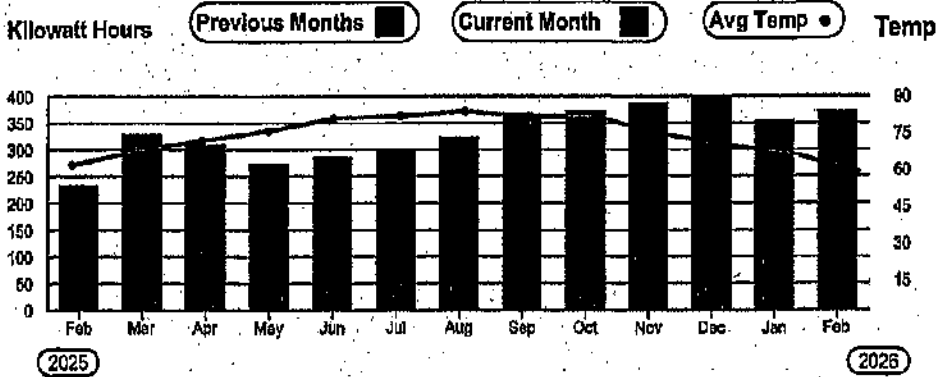

Detailed usage information is available on the SmartHub App or www.precio.coop

Monthly Energy Use Comparison

372
kWh

This Month
31 Days

355
kWh

Last Month
30 Days

233
kWh

This Month
Last Year
31 Days

Your Average Daily Use

12
kWh

Use

\$18.45
Day

Cost
not including
taxes and fees

Please make check payable to PRECO in U.S. funds and return this portion with your payment.



Peace River Electric Cooperative, Inc.

PO Box 1310
210 Metheny Road
Wauchula, Florida 33873
800.282.3824

Account #
Service Address

160096003
6810 TREVESTA PL

Bank Draft Amount \$600.59
is scheduled for 03/10/2026



TREVESTA CDD
PO BOX 32414
CHARLOTTE NC 28232-2414

PEACE RIVER ELECTRIC COOPERATIVE, INC.
PO BOX 1547
WAUCHULA FL 33873-1547



Account
160096003

Service Address
6810 TREVISTA PL

Service Description
STREET LIGHTS

Board District
8

Meter #	Service Period		Readings		Meter Multiplier	kWh Usage	kW Reading
	From	To	Previous	Present			
34427038	01/09/2026	02/09/2026	100.500	100.872	1.0	372	0.75

Account Summary

Previous Balance	\$599.20
Payment(s) Made	-\$599.20
Balance Forward	\$0.00
Current Charges	\$600.59
Total Amount Due	\$600.59

Current Charges	GSD-S
Facilities Use Charge	\$110.00
Energy Charge	372 kWh @ 0.083 \$30.88
CPA	372 kWh @ -0.005 -\$1.86
Billed Demand	60.000 kW @ 8.660 \$433.00
Property Tax Recovery Fee	\$13.56
Gross Receipts Tax	\$15.01
Total Current Charges	\$600.59

Bank Draft Amount \$600.59



PRECO Offers

\$140,000 in College Scholarships

Application deadline is February 28
Apply online at www.precocoop/community/scholarships



Now offering cash bill-pay service at participating retail stores. The barcode below can be scanned at the register, allowing you to make your monthly payment. There is a \$1.50 convenience fee to use this service. To find a location near you, visit pay.vanilladirect.com/pages/retailers



799366433650001102601600960033

By accepting or using this barcode to make a payment, you agree to the full terms and conditions, available at vanilladirect.com/pay/terms. After successful payment using this barcode, you may retrieve your full detailed e-receipt at vanilladirect.com/pay/ereceipt.

The majority of participating locations will accept cash payments up to a maximum amount of \$500.00.

FAMILY DOLLAR

CVS

Walgreens

DOLLAR GENERAL





Peace River Electric Cooperative, Inc.

TREVESTA CDD

Bill Date
Account #
Member #

02/17/2026
160096004
159427

Customer Care 800-282-3824 8am - 5pm M-F
Pay by Phone 855-937-1752
Outage 800-282-3824 24/7
Website www.precocoop



TOTAL AMOUNT DUE

\$161.29

Bank Draft is scheduled for 03/10/2026

Monthly Energy Use

Kilowatt Hours Previous Months Current Month Avg Temp Temp

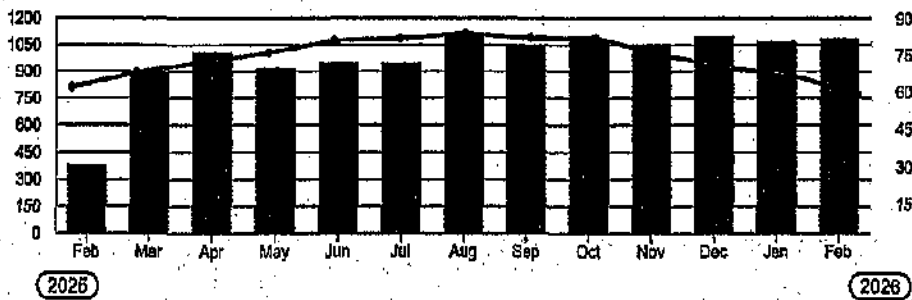

Detailed usage information is available on the SmartHub App or www.precocoop

Monthly Energy Use Comparison

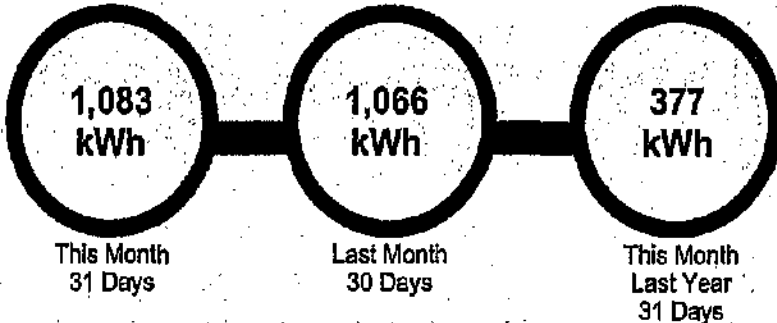

Your Average Daily Use

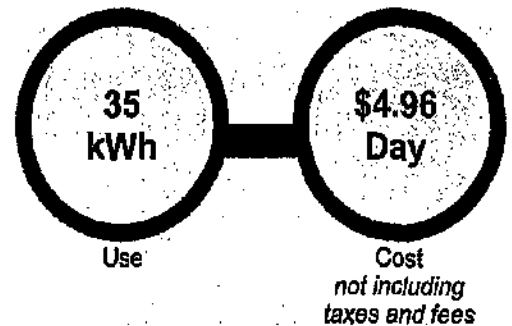

Please make check payable to PRECO in U.S. funds and return this portion with your payment.



Peace River Electric Cooperative, Inc.

PO Box 1310
210 Metheny Road
Wauchula, Florida 33873
800.282.3824

Account # 160096004
Service Address 6581 DEVESTA LOOP

Bank Draft Amount \$161.29
is scheduled for 03/10/2026



TREVESTA CDD
PO BOX 32414
CHARLOTTE NC 28232-2414

PEACE RIVER ELECTRIC COOPERATIVE, INC.
PO BOX 1547
WAUCHULA FL 33873-1547



Account
160096004

Service Address
6581 DEVESTA LOOP

Service Description
FOUNTAIN

Board District
8



Meter #	Service Period		Readings		Meter Multiplier	kWh Usage	kW Reading
	From	To	Previous	Present			
34842876	01/09/2026	02/09/2026	176,443	176,526	1.0	1,083	2,518

Account Summary

Previous Balance	\$159.23
Payment(s) Made	-\$159.23
Balance Forward	\$0.00
Current Charges	\$161.29
Total Amount Due	\$161.29

Current Charges	GS-S
Facilities Use Charge	\$28.00
Energy Charge	1,083 kWh @ 0.121 \$131.04
CPA	1,083 kWh @ -0.005 -\$5.42
Property Tax Recovery Fee	\$3.64
Gross Receipts Tax	\$4.03
Total Current Charges	\$161.29

Bank Draft Amount \$161.29



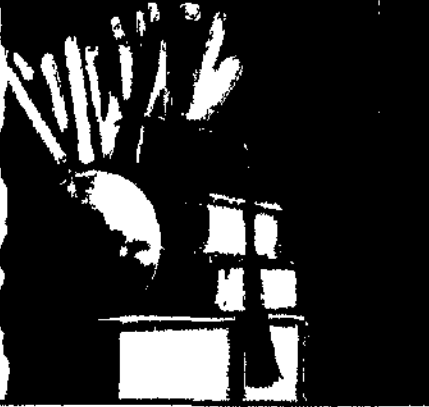

PRECO Offers \$140,000 in College Scholarships

Application deadline is February 28
Apply online at www.preco.coop/community/scholarships









Now offering cash bill-pay service at participating retail stores. The barcode below can be scanned at the register, allowing you to make your monthly payment. There is a \$1.50 convenience fee to use this service. To find a location near you, visit pay.vanilladirect.com/pages/retailers



799366433650001102601600960041

By accepting or using this barcode to make a payment, you agree to the full terms and conditions, available at vanilladirect.com/pay/terms. After successful payment using this barcode, you may retrieve your full detailed e-receipt at vanilladirect.com/pay/receipt.

The majority of participating locations will accept cash payments up to a maximum amount of \$500.00.





Peace River Electric Cooperative, Inc.

TREVESTA CDD

Bill Date
Account #
Member #

02/17/2026
160096005
159427

Customer Care 800-282-3824 8am - 5pm M-F
Pay by Phone 855-937-1752
Outage 800-282-3824 24/7
Website www.preco.coop



TOTAL
AMOUNT DUE

\$297.59

Bank Draft is
scheduled for
03/10/2026

Monthly Energy Use

Kilowatt Hours Previous Months Current Month Avg Temp Temp

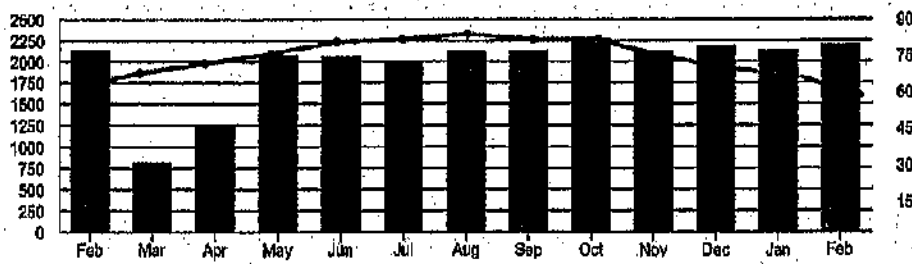

2025

2026

Detailed usage information is available on the SmartHub App or www.preco.coop

Monthly Energy Use Comparison

2,202
kWh

This Month
31 Days

2,136
kWh

Last Month
30 Days

2,137
kWh

This Month
Last Year
31 Days

Your Average Daily Use

71
kWh

Use

\$9.14
Day

Cost
not including
taxes and fees

Please make check payable to PRECO in U.S. funds and return this portion with your payment.



Peace River Electric Cooperative, Inc.

PO Box 1310
210 Metheny Road
Wauchula, Florida 33873
800.282.3824

Account #
Service Address

160096005
6727 DEVESTA LOOP

Bank Draft Amount \$297.59
is scheduled for 03/10/2026



TREVESTA CDD
PO BOX 32414
CHARLOTTE NC 28232-2414

PEACE RIVER ELECTRIC COOPERATIVE, INC.
PO BOX 1547
WAUCHULA FL 33873-1547



Account
160096005

Service Address
6727 DEVESTA LOOP

Service Description
FOUNTAIN

Board District
8

Meter #	Service Period		Readings		Meter Multiplier	kWh Usage	kW Reading
	From	To	Previous	Present			
34710733	01/09/2026	02/09/2026	196,434	198,636	1.0	2,202	5.136

Account Summary

Previous Balance
Payment(s) Made
Balance Forward
Current Charges
Total Amount Due

\$289.56
-\$289.56
\$0.00
\$297.59
\$297.59

Current Charges

Facilities Use Charge \$28.00
Energy Charge 2,202 kWh @ 0.121 \$266.44
CPA 2,202 kWh @ -0.005 -\$11.01
Property Tax Recovery Fee \$6.72
Gross Receipts Tax \$7.44
Total Current Charges \$297.59

GS-S

Bank Draft Amount

\$297.59



PRECO Offers

\$140,000 in

College Scholarships

Application deadline is February 28

Apply online at www.precocoop/community/scholarships



Now offering cash bill-pay service at participating retail stores. The barcode below can be scanned at the register, allowing you to make your monthly payment. There is a \$1.50 convenience fee to use this service. To find a location near you, visit pay.vanilladirect.com/pages/retailers



799366433650001102601600960058

By accepting or using this barcode to make a payment, you agree to the full terms and conditions, available at vanilladirect.com/bav/terms. After successful payment using this barcode, you may retrieve your full detailed e-receipt at vanilladirect.com/bav/receipt.

The majority of participating locations will accept cash payments up to a maximum amount of \$500.00.

FAMILY DOLLAR

CVS

Walgreens

DOLLAR GENERAL





Peace River Electric Cooperative, Inc.

TREVESTA CDD

Bill Date
Account #
Member #

02/17/2026
160096006
159427

Customer Care 800-282-3824 8am - 5pm M-F
Pay by Phone 855-937-1752
Outage 800-282-3824 24/7
Website www.presco.coop



TOTAL AMOUNT DUE

\$40.47

Bank Draft is scheduled for 03/10/2026

Monthly Energy Use

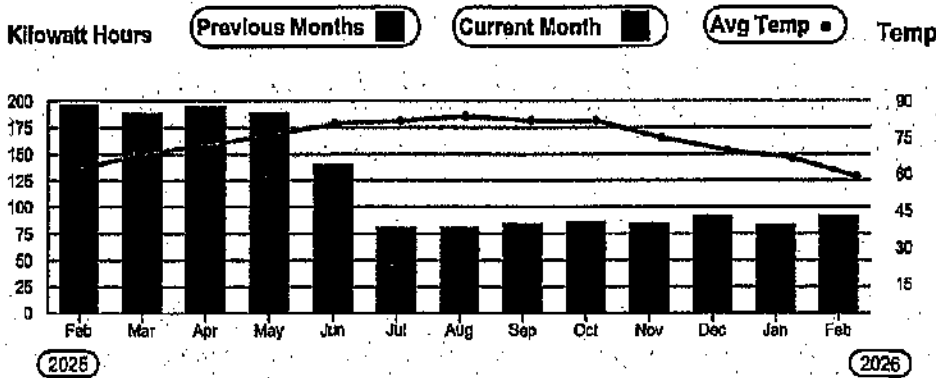

Detailed usage information is available on the SmarHub App or www.presco.coop

Monthly Energy Use Comparison

91 kWh

This Month
31 Days

83 kWh

Last Month
30 Days

197 kWh

This Month
Last Year
31 Days

Your Average Daily Use

3 kWh

Use

\$1.24 Day

Cost
not including
taxes and fees

Please make check payable to PRECO in U.S. funds and return this portion with your payment.



Peace River Electric Cooperative, Inc.

PO Box 1310
210 Methery Road
Wauchula, Florida 33873
800.282.3824

Account #
Service Address

160096006
6405 TREVESTA PL

Bank Draft Amount \$40.47
is scheduled for 03/10/2026



TREVESTA CDD
PO BOX 32414
CHARLOTTE NC 28232-2414

PEACE RIVER ELECTRIC COOPERATIVE, INC.
PO BOX 1547
WAUCHULA FL 33873-1547



Account
160096008

Service Address
6405 TREVISTA PL

Service Description
PUMP

Board District
8

Meter #	Service Period		Readings		Meter Multiplier	kWh Usage	kW Reading
	From	To	Previous	Present			
929096871	01/09/2026	02/09/2026	13,749	13,840	1.0	91	0.126

Account Summary

Previous Balance	\$576.91
Payment(s) Made	-\$576.91
Balance Forward	\$0.00
Current Charges	\$40.47
Total Amount Due	\$40.47

Current Charges	GS-S
Facilities Use Charge	\$28.00
Energy Charge	91 kWh @ 0.121 \$11.01
CPA	91 kWh @ -0.005 -\$0.46
Property Tax Recovery Fee	\$0.91
Gross Receipts Tax	\$1.01
Total Current Charges	\$40.47

Bank Draft Amount \$40.47





PRECO Offers \$140,000 in College Scholarships

Application deadline is February 28
Apply online at www.preco.coop/community/scholarships









Now offering cash bill-pay service at participating retail stores. The barcode below can be scanned at the register, allowing you to make your monthly payment. There is a \$1.50 convenience fee to use this service. To find a location near you, visit pay.vanilladirect.com/pages/retailers



799366433650001102601600960066

By accepting or using this barcode to make a payment, you agree to the full terms and conditions, available at vanilladirect.com/pav/terms. After successful payment using this barcode, you may retrieve your full detailed e-receipt at vanilladirect.com/pav/receipt.

The majority of participating locations will accept cash payments up to a maximum amount of \$500.00.





Peace River Electric Cooperative, Inc.

TREVESTA CDD

Bill Date
Account #
Member #

02/17/2026
160096007
159427

Customer Care 800-282-3824 8am - 5pm M-F
Pay by Phone 855-837-1752
Outage 800-282-3824 24/7
Website www.preco.coop



TOTAL AMOUNT DUE

\$64.59

Bank Draft is scheduled for 03/10/2026

Monthly Energy Use

Kilowatt Hours Previous Months Current Month Avg Temp Temp

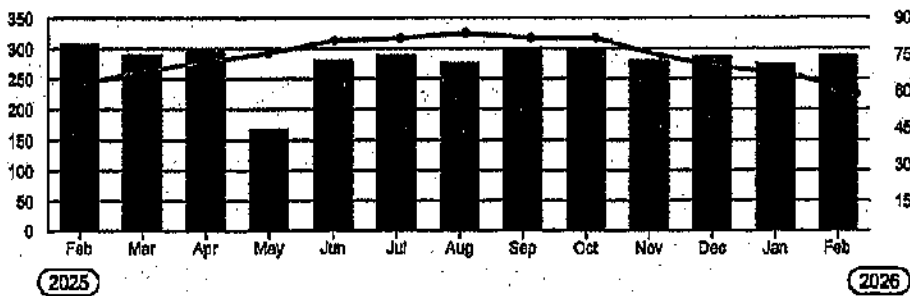

Detailed usage information is available on the SmarHub App or www.preco.coop

Monthly Energy Use Comparison

289 kWh

This Month
31 Days

276 kWh

Last Month
30 Days

308 kWh

This Month
Last Year
31 Days

Your Average Daily Use

9 kWh

Use

\$1.98 Day

Cost
not including
taxes and fees

Please make check payable to PRECO in U.S. funds and return this portion with your payment.



Peace River Electric Cooperative, Inc.

PO Box 1310
210 Methery Road
Wauchula, Florida 33873
800.282.3824

Account # 160096007
Service Address 6227 KEVESTA AVE

Bank Draft Amount \$64.59
is scheduled for 03/10/2026



TREVESTA CDD
PO BOX 32414
CHARLOTTE NC 28232-2414

PEACE RIVER ELECTRIC COOPERATIVE, INC.
PO BOX 1547
WAUCHULA FL 33873-1547



Account
160096007

Service Address
6227 KEVESTA AVE

Service Description
PUMP

Board District
8

Meter #	Service Period		Readings		Meter Multiplier	kWh Usage	kW Reading
	From	To	Previous	Present			
36675115	01/09/2026	02/09/2026	23,555	23,844	1.0	289	0.408

Account Summary

Previous Balance	\$63.02
Payment(s) Made	-\$63.02
Balance Forward	\$0.00
Current Charges	\$64.59
Total Amount Due	\$64.59

Current Charges	GS-S
Facilities Use Charge	\$28.00
Energy Charge	289 kWh @ 0.121 \$34.97
CPA	289 kWh @ -0.005 -\$1.45
Property Tax Recovery Fee	\$1.48
Gross Receipts Tax	\$1.61
Total Current Charges	\$64.59

Bank Draft Amount \$64.59



PRECO Offers \$140,000 in College Scholarships

Application deadline is February 28
Apply online at www.preco.coop/community/scholarships



Now offering cash bill-pay service at participating retail stores. The barcode below can be scanned at the register, allowing you to make your monthly payment. There is a \$1.50 convenience fee to use this service. To find a location near you, visit pay.vanilladirect.com/pages/retailers



799366433650001102601600960074

By accepting or using this barcode to make a payment, you agree to the full terms and conditions, available at vanilladirect.com/pay/terms. After successful payment using this barcode, you may retrieve your full detailed e-receipt at vanilladirect.com/pay/receipt.

The majority of participating locations will accept cash payments up to a maximum amount of \$500.00.





Peace River Electric Cooperative, Inc.

TREVESTA CDD

Bill Date
Account #
Member #

02/17/2026
160096008
159427

Customer Care 800-282-3824 8am - 5pm M-F
Pay by Phone 855-937-1752
Outage Website 800-282-3824 24/7
www.precocoop



TOTAL AMOUNT DUE

\$66.30

Bank Draft is scheduled for 03/10/2026

Monthly Energy Use

Kilowatt Hours Previous Months Current Month Avg Temp Temp

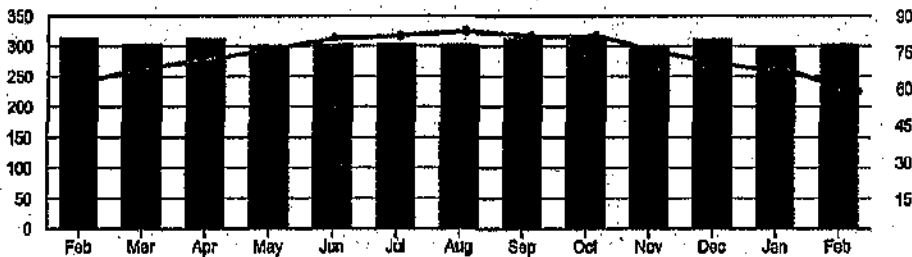

Detailed usage information is available on the SmartHub App or www.precocoop

Monthly Energy Use Comparison

Your Average Daily Use

303
kWh

This Month
31 Days

299
kWh

Last Month
30 Days

314
kWh

This Month
Last Year
31 Days

10
kWh

Use

\$2.04
Day

Cost
not including
taxes and fees

Please make check payable to PRECO in U.S. funds and return this portion with your payment.



Peace River Electric Cooperative, Inc.

PO Box 1310
210 Metheny Road
Wauchula, Florida 33873
800.282.3824

Account # 160096008
Service Address 6234 KEVESTA AVE

Bank Draft Amount \$66.30
is scheduled for 03/10/2026



TREVESTA CDD
PO BOX 32414
CHARLOTTE NC 28232-2414

PEACE RIVER ELECTRIC COOPERATIVE, INC.
PO BOX 1547
WAUCHULA FL 33873-1547



Account
160096008

Service Address
6234 KEYESTA AVE

Service Description
AERATOR

Board District
8

Meter #	Service Period		Readings		Meter Multiplier	kWh Usage	kW Reading
	From	To	Previous	Present			
38695968	01/09/2026	02/09/2026	10,217	10,520	1.0	303	0.422

Account Summary

Previous Balance	\$65.82
Payment(s) Made	-\$65.82
Balance Forward	\$0.00
Current Charges	\$66.30
Total Amount Due	\$66.30

Current Charges	GS-S
Facilities Use Charge	\$28.00
Energy Charge	303 kWh @ 0.121 \$36.66
CPA	303 kWh @ -0.005 -\$1.52
Property Tax Recovery Fee	\$1.50
Gross Receipts Tax	\$1.66
Total Current Charges	\$66.30

Bank Draft Amount \$66.30





PRECOCOP Offers
\$140,000 in
College Scholarships

Application deadline is February 28
Apply online at www.precocop.com/community/scholarships



Now offering cash bill-pay service at participating retail stores. The barcode below can be scanned at the register, allowing you to make your monthly payment. There is a \$1.50 convenience fee to use this service. To find a location near you, visit pay.vanilladirect.com/pages/retailers

799366433650001102601600960082

By accepting or using this barcode to make a payment, you agree to the full terms and conditions, available at vanilladirect.com/pay/terms. After successful payment using this barcode, you may retrieve your full detailed e-receipt at vanilladirect.com/pay/ereceipt.

The majority of participating locations will accept cash payments up to a maximum amount of \$500.00.



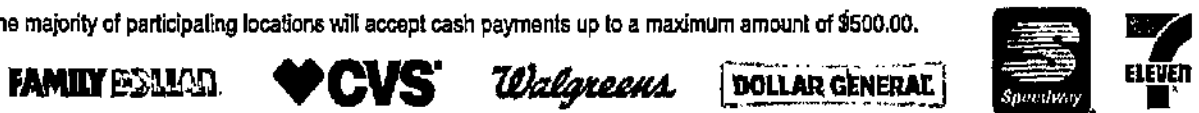

Invoice # 127983

BI # 9246

03/11/2026

EMAIL TO ADMIN
TREVETA CDD
C/O RIZZETTA & COMPANY
TAMPA FL 33614

TREVETA COMMUNITY DEVELOPMENT
DISTRICT (MANATEE COUNTY, FLORIDA)
SPECIAL ASSESSMENT BONDS,
SERIES 2018 (ASSESSMENT AREA ONE
PHASE 2 PROJECT) BI # 9246

Please remit the following for Trustee, Paying Agent, Registrar, Custodial or Escrow Agent Fee.

Due Date 01/01/2026

ANNUAL FEE \$3,500.00

Total Due: \$3,500.00

Detach and remit with payment to the address below. If paying by wire, please remit to the following instructions.

Thank you for choosing Regions Bank

9246

Due Date 01/01/2026

Amount Due \$3,500.00

Please contact your administrator with any questions or concerns.

JANET RICARDO

904-565-7973



MAR - 9 2026

Invoice # 129538

BI # 7587

02/26/2026

TREVESTA CDD
C/O RIZZETTA & COMPANY
3434 COLWELL AVENUE, STE 200
TAMPA FL 33614

**TREVESTA COMMUNITY DEVELOPMENT
DISTRICT SPECIAL ASSESSMENT BONDS
SERIES 2016 A-1 BI # 7587**

Please remit the following for Trustee, Paying Agent, Registrar, Custodial or Escrow Agent Fee.

Due Date 04/01/2026

ANNUAL FEE

\$3,500.00

Total Due: \$3,500.00

Detach and remit with payment to the address below. If paying by wire, please remit to the following instructions.

Thank you for choosing Regions Bank

7587

Due Date 04/01/2026

Amount Due \$3,500.00

Please contact your administrator with any questions or concerns.

JANET RICARDO

904-565-7973

Rizzetta & Company, Inc.
 3434 Colwell Avenue
 Suite 200
 Tampa FL 33614

Invoice

Date	Invoice #
3/2/2026	INV0000107442

Bill To:

TREVESTA CDD 3434 Colwell Avenue Suite 200 Tampa FL 33614
--

Services for the month of	Terms	Client Number
March	Upon Receipt	00241

Description	Qty	Rate	Amount
Accounting Services	1.00	\$1,772.58	\$1,772.58
Administrative Services	1.00	\$443.17	\$443.17
Dissemination Services	1.00	\$583.33	\$583.33
Email Accounts, Admin & Maintenance	5.00	\$20.00	\$100.00
Financial & Revenue Collections	1.00	\$354.50	\$354.50
Landscape Consulting Services	1.00	\$1,000.00	\$1,000.00
Management Services	1.00	\$2,107.33	\$2,107.33
Website Compliance & Management	1.00	\$100.00	\$100.00
Subtotal			\$6,460.91
Total			\$6,460.91

INVOICE

Sitex Aquatics, LLC
PO Box 917
Parrish, FL 34219

office@sitexaquatics.com
+1 (813) 564-2322



Bill to

Trevesta CDD
Rizzetta
P.O. Box 32414 Charlotte, NC 28232

Invoice details

Invoice no.: 10853-b
Terms: Net 30
Invoice date: 03/01/2026
Due date: 03/31/2026

#	Date	Product or service	Description	Qty	Rate	Amount
1.		Aquatic Maintenance	Monthly Lake Maintenance-19 Waterways	1	\$2,255.00	\$2,255.00
					Total	\$2,255.00

TREVESTA COMMUNITY DEVELOPMENT DISTRICT

District Office · Riverview · Florida · 813-994-1001

Mailing Address – 3434 Colwell Avenue, Suite 200, Tampa, Florida 33614

Operation and Maintenance Expenditures

April 2026

For Board Approval

Attached please find the check register listing the Operation and Maintenance expenditures paid from April 1, 2026 through April 30, 2026. This does not include expenditures previously approved by the Board.

The total items being presented: **\$29,471.09**

Approval of Expenditures:

_____ Chairperson

_____ Vice Chairperson

_____ Assistant Secretary

Trevesta Community Development District

Paid Operation & Maintenance Expenditures

April 1, 2026 Through April 30, 2026

<u>Vendor Name</u>	<u>Check Number</u>	<u>Invoice Number</u>	<u>Invoice Description</u>	<u>Invoice Amount</u>
Bloomings Landscape & Turf Management, Inc.	100571	2026-00557	Water trailer 03/26	\$ 1,050.00
David P Hoyt	100575	DH040826	Board of Supervisors Meeting 04/08/2026	\$ 200.00
Dean LaFollette	100576	DL040826	Board of Supervisors Meeting 04/08/2026	\$ 200.00
FWU Environmental Services	100579	90183249	Water Service 01/26	\$ 4,655.20
FWU Environmental Services	100581	90184543	Water Service 04/26	\$ 4,655.20
Joseph Powlis	20260410-1	JP040826 ACH	Board of Supervisors Meeting 04/08/2026	\$ 200.00
Kilinski Van Wyk, PLLC	100578	14539	Legal Services 02/26	\$ 2,626.35
Peace River Electric Cooperative, Inc.	20260407-8	160096001-031726 ACH	6204 Buffalo Road 02/26	\$ 40.47
Peace River Electric Cooperative, Inc.	20260407-7	160096002-031726 ACH	6810 Trevesta PL 02/26	\$ 1,052.17
Peace River Electric Cooperative, Inc.	20260407-6	160096003-031726 ACH	6810 Trevesta PL 02/26	\$ 597.07
Peace River Electric Cooperative, Inc.	20260407-5	160096004-031726 ACH	6581 Devesta Loop 02/26	\$ 158.26
Peace River Electric Cooperative, Inc.	20260407-4	160096005-031726 ACH	6727 Devesta Loop 02/26	\$ 290.04
Peace River Electric Cooperative, Inc.	20260407-3	160096006-031726 ACH	6405 Trevesta Place 02/26	\$ 39.50
Peace River Electric Cooperative, Inc.	20260407-2	160096007-031726 ACH	6227 Kevesta AVE 02/26	\$ 64.72

Trevesta Community Development District

Paid Operation & Maintenance Expenditures

April 1, 2026 Through April 30, 2026

<u>Vendor Name</u>	<u>Check Number</u>	<u>Invoice Number</u>	<u>Invoice Description</u>	<u>Invoice Amount</u>
Peace River Electric Cooperative, Inc.	20260407-1	160096008-031726	ACH 6234 Kevesta Ave 02/26	\$ 65.20
Rizzetta & Company, Inc.	100572	INV0000108036	Accounting Services 04/26	\$ 6,460.91
Sitex Aquatics, LLC	100574	10870-b	Fountain Repairs 03/26	\$ 185.00
Sitex Aquatics, LLC	100580	10911-b	Quarterly Fountain Cleaning 04/26	\$ 1,000.00
Sitex Aquatics, LLC	100580	10963-b	Monthly Lake Maintenance 04/26	\$ 2,255.00
Stantec Consulting Services, Inc.	100573	2542860	Engineering Services 02/26	\$ 1,404.00
Stantec Consulting Services, Inc.	100582	2548489	Engineering Services 04/26	\$ 1,872.00
Theodore R. Piwowar	100577	TP040826	Board of Supervisors Meeting 04/08/2026	\$ 200.00
William J Dornetto Jr	20260410-2	WD040826	ACH Board of Supervisors Meeting 04/08/2026	\$ <u>200.00</u>
Report Total				\$ <u>29,471.09</u>



Invoice

5824 Bee Ridge Road #165, Sarasota, FL 34233

Date **Invoice #**
 3/26/2026 2026-00557

Bill To:

Trevesta CDD
c/o Rizzetta & Company, Inc.
2700 S. Faulkenberg Rd
Riverview, FL 33578

		Terms	Due on receipt
Description	Qty	Rate	Amount
Water Trailer - Trevesta Blvd turf & shrubs, Pocket Park & Buffalo Rd Viburnum			
Water Trailer	6	175.00	1,050.00

PAYMENT ACCEPTED: BANK TRANSFER (ACH) & CREDIT CARD.
 Please note that there is a 3% Processing Fee on Credit Card Payments.

Thank You For Your Business.

Total	\$1,050.00
Payments/Credits	\$0.00
Balance Due	\$1,050.00

Phone # **Fax #** **E-mail** **Web Site**
 (941) 927-9765 amy@bloomingslandscape.com www.bloomingslandscape.com

TREVESTA CDD

Meeting April 8, 2026

SUPERVISOR PAY REQUEST

Name of Board Supervisor	Check if paid
Dave Hoyt	<input checked="" type="checkbox"/>
Dean Lafollette	<input checked="" type="checkbox"/>
William Dornetto ACH	<input checked="" type="checkbox"/>
Joseph Powlis ACH	<input checked="" type="checkbox"/>
Ted Piwowar	<input checked="" type="checkbox"/>

NOTE: Supervisors are only paid if checked.

EXTENDED MEETING TIMECARD

Meeting Start Time:	3:00 PM
Meeting End Time:	5:23 PM
Total Meeting Time:	2H 23min

Time Over _____ (3) Hours:

Total at \$175 per Hour:

ADDITIONAL OR CONTINUED MEETING TIMECARD

Meeting Date:	<input type="text"/>
Additional or Continued Meeting?	<input type="text"/>
Total Meeting Time:	<input type="text"/>
Total at \$175 per Hour:	<input type="text"/>

Business Mileage Round Trip	<input type="text"/>
IRS Rate per Mile	\$0.700
Mileage to Charge	<input type="text"/>

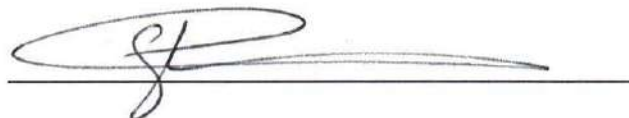
DM Signature: 

INVOICE



Florida Water Utilities

Environmental Services

A SouthWest Water Company

Invoice # : 90183249
Invoice Date : 01-07-2026

Remit Payment To:
FWU Environmental Services
P.O. Box 290910
Columbia, SC 29229
Phone: (803) 995-5070
Fax: (803) 699-2423
Email: meagan.douglas@nexuswg.com
www.nexuswg.com

Bill-To:
Trevesta CDD
Rizzetta Mangement Services
9428 CAMDEN FIELD PKWY
RIVERVIEW, FL 33578-0519

Table with 4 columns: Payment Terms, Due Date, Representative, District. Row 1: Payable upon receipt, 01-07-2026, Trevesta, Trevesta

Table with 4 columns: Service Performed, Quantity, Rate, Amount. Rows: Phase 1A Common Area (5.300, 264.50, 1,401.85), Phase 1B Common Area (5.300, 264.50, 1,401.85), Phase 2 Common Area (7, 264.50, 1,851.50)

Summary table with 2 columns: Category, Amount. Rows: Subtotal (4,655.20), Sales Tax (0.00), Total (4,655.20)

INVOICE



Florida Water Utilities

Environmental Services

A SouthWest Water Company

Invoice # : 90184543

Invoice Date : 04-21-2026

Remit Payment To:

FWU Environmental Services

P.O. Box 290910

Columbia, SC 29229

Phone: (803) 995-5070

Email: meagan.douglas@nexuswg.com

www.nexuswg.com

Bill-To:

Trevesta CDD

Rizzetta Mangement Services

9428 CAMDEN FIELD PKWY

RIVERVIEW, FL 33578-0519

Payment Terms	Due Date	Representative	District
Payable upon receipt	04-21-2026		Trevesta

Service Performed	Quantity	Rate	Amount
Phase 1A Common Area	5.300	264.50	1,401.85
Phase 1B Common Area	5.300	264.50	1,401.85
Phase 2 Common Area	7	264.50	1,851.50

Subtotal	4,655.20
Sales Tax	0.00
Total	4,655.20



KILINSKI | VAN WYK

Kilinski | Van Wyk PLLC

P.O. Box 6386
Tallahassee, Florida 32314
United States

Trevesta CDD
2700 S. Falkenburg Rd. Suite 2745
Riverview, Florida 33578

INVOICE

Invoice # 14539
Date: 03/19/2026
Due On: 04/18/2026

Statement of Account

Outstanding Balance	New Charges	Payments Received	Total Amount Outstanding
(\$1,893.50	+ \$2,626.35)-(\$0.00	\$4,519.85

TRVCDD-01

Trevesta CDD - General

Type	Attorney	Date	Notes	Quantity	Rate	Discount	Total
Service	MH	02/03/2026	Confer with Supervisor Hoyt, District Manager, and VK Trevesta, LLC counsel regarding F3 tract conveyance. Review deed.	0.30	\$375.00	-	\$112.50
Service	SD	02/06/2026	Receive "Deed to CDD Tr F3 202641010304" and update district files regarding same.	0.10	\$190.00	-	\$19.00
Service	PC	02/09/2026	Analysis of agenda for 02/11/2026 meeting of the Board of Supervisors including review of staff reports, organizational matters, vendor proposals, and district financial statements; Analysis of Manatee County official records, land use code, and SWFWMD reporting	1.90	\$300.00	-	\$570.00

requirements in order to ascertain preserve area maintenance requirements; Submit public records request for development approval documents.

Service	MH	02/11/2026	Prepare for and attend Board meeting.	1.30	\$375.00	100.0%	\$0.00
Service	PC	02/11/2026	Attend 02/11/2026 meeting of the Board of Supervisors.	4.00	\$300.00	-	\$1,200.00
Expense	KB	02/11/2026	Travel: Mileage - PC.	49.00	\$0.725	-	\$35.53
Expense	KB	02/11/2026	Travel: Tolls - PC.	1.00	\$2.32	-	\$2.32
Service	PC	02/12/2026	Correspond with District Manager regarding action items following February meeting of the Board of Supervisors; Draft additional services order for February landscaping approvals.	0.50	\$300.00	-	\$150.00
Service	MH	02/13/2026	Confer with District staff regarding wetland maintenance and required contractual provisions.	0.20	\$375.00	-	\$75.00
Service	PC	02/13/2026	Draft agreement for wetland and environmental management services with Eco-Logic.	1.10	\$300.00	-	\$330.00
Service	JK	02/23/2026	Monitor and report on bills affecting special districts.	0.20	\$375.00	-	\$75.00
Service	CD	02/28/2026	Research District Website; Draft Appropriation Resolution and Budget Resolutions for FY2027 with Letters, and Affidavit of Mailing and email to District Staff for review.	0.30	\$190.00	-	\$57.00

Line Item Discount Subtotal **-\$487.50**

Total **\$2,626.35**

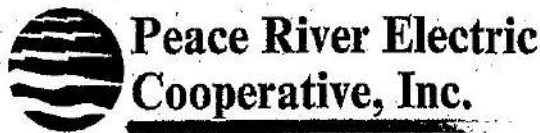

TREVESTA CDD

Bill Date
Account #
Member #

03/17/2026
160096001
159427

Customer Care 800-282-3824 8am - 5pm M-F
Pay by Phone 855-937-1752
Outage 800-282-3824 24/7
Website www.precio.coop



TOTAL AMOUNT DUE
\$40.47
Bank Draft Is scheduled for 04/07/2026

Monthly Energy Use

Kilowatt Hours Previous Months Current Month Avg Temp Temp

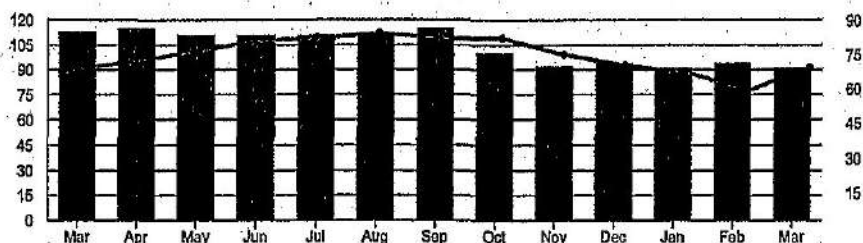

Detailed usage information is available on the SmarHub App or www.precio.coop

Monthly Energy Use Comparison

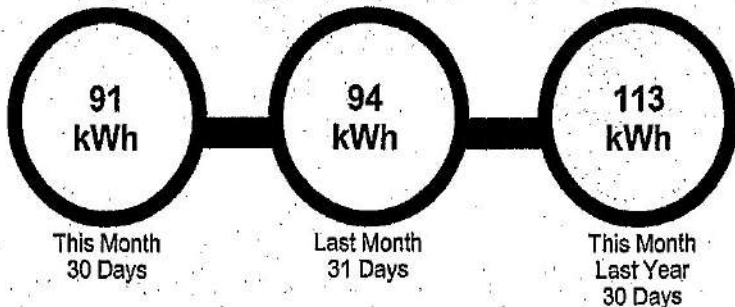

Your Average Daily Use

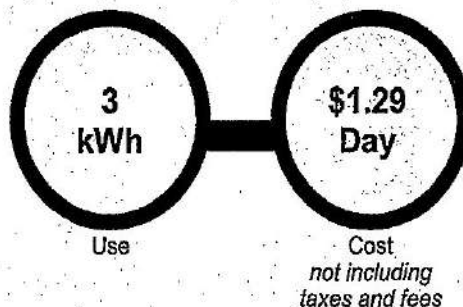

Please make check payable to PRECO in U.S. funds and return this portion with your payment.



Peace River Electric Cooperative, Inc.

PO Box 1310
210 Metheny Road
Wauchula, Florida 33873
800.282.3824

Account #
Service Address

160096001
6204 BUFFALO RD

Bank Draft Amount \$40.47
is scheduled for 04/07/2026



TREVESTA CDD
PO BOX 32414
CHARLOTTE NC 28232-2414

PEACE RIVER ELECTRIC COOPERATIVE, INC.
PO BOX 1547
WAUCHULA FL 33873-1547



Account
160096001

Service Address
6204 BUFFALO RD

Service Description
175 TOWER SIGN

Board District
8

Meter #	Service Period		Readings		Meter Multiplier	kWh Usage	kW Reading
	From	To	Previous	Present			
34330156	02/09/2026	03/11/2026	18,206	18,297	1.0	91	0.126
Account Summary					Current Charges		GS-S
Previous Balance			\$40.84	Facilities Use Charge			\$28.00
Payment(s) Made			-\$40.84	Energy Charge		91 kWh @ 0.121	\$11.01
Balance Forward			\$0.00	CPA		91 kWh @ -0.005	-\$0.46
Current Charges			\$40.47	Property Tax Recovery Fee			\$0.91
Total Amount Due			\$40.47	Gross Receipts Tax			\$1.01
				Total Current Charges			\$40.47
Bank Draft Amount							\$40.47

NEVER MISS AN ISSUE

Life gets busy. Mail gets misplaced.

The digital edition of the Florida Currents arrives straight to your inbox, every time.

Same trusted stories. Same cooperative news. Just delivered smarter.

Sign up for the digital edition of the Florida Currents Magazine



Now offering cash bill-pay service at participating retail stores. The barcode below can be scanned at the register, allowing you to make your monthly payment. There is a \$1.50 convenience fee to use this service. To find a location near you, visit pay.vanilladirect.com/pages/retailers



799366433650001102601600960017

By accepting or using this barcode to make a payment, you agree to the full terms and conditions, available at vanilladirect.com/pay/terms. After successful payment using this barcode, you may retrieve your full detailed e-receipt at vanilladirect.com/pay/ereceipt.

The majority of participating locations will accept cash payments up to a maximum amount of \$500.00.





Peace River Electric Cooperative, Inc.

TREVESTA CDD

Bill Date
Account #
Member #

03/17/2026
160096002
159427

Customer Care | 800-282-3824 8am - 5pm M-F
Pay by Phone | 855-937-1752
Outage | 800-282-3824 24/7
Website | www.preco.coop



TOTAL AMOUNT DUE

\$1,052.17

Bank Draft is scheduled for
04/07/2026

Monthly Energy Use

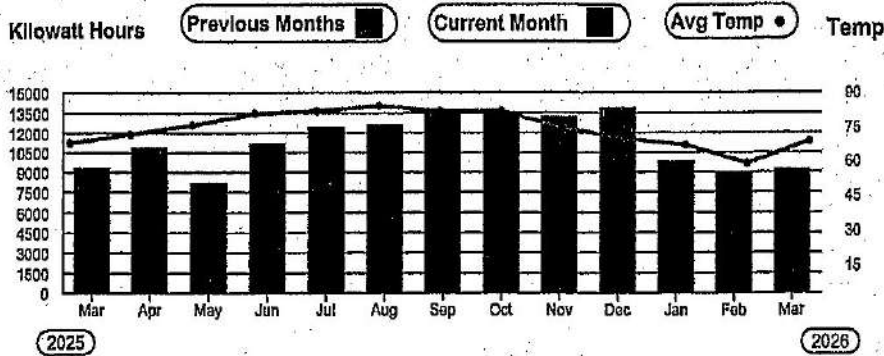

Detailed usage information is available on the SmartHub App or www.preco.coop

Monthly Energy Use Comparison

9,217
kWh

This Month
30 Days

9,056
kWh

Last Month
31 Days

9,336
kWh

This Month
Last Year
30 Days

Your Average Daily Use

307
kWh

Use

\$33.40
Day

Cost
not including
taxes and fees

Please make check payable to PRECO in U.S. funds and return this portion with your payment.



Peace River Electric Cooperative, Inc.

PO Box 1310
210 Metheny Road
Wauchula, Florida 33873
800.282.3824

Account #
Service Address

160096002
6810 TREVESTA PL

Bank Draft Amount \$1,052.17
is scheduled for 04/07/2026



TREVESTA CDD
PO BOX 32414
CHARLOTTE NC 28232-2414

PEACE RIVER ELECTRIC COOPERATIVE, INC.
PO BOX 1547
WAUCHULA FL 33873-1547



Account
160096002

Service Address
6810 TREVESTA PL

Service Description
ENTRANCE TOWER/MONUMENT SIGN

Board District
8

Meter #	Service Period		Readings		Meter Multiplier	kWh Usage	kW Reading
	From	To	Previous	Present			
34330124	02/09/2026	03/11/2026	912,814	922,031	1.0	9,217	18,858
Account Summary					Current Charges		GSD
Previous Balance			\$1,038.99		Facilities Use Charge		\$110.00
Payment(s) Made			-\$1,038.99		Energy Charge	9,217 kWh @ 0.083	\$765.01
Balance Forward			\$0.00		CPA	9,217 kWh @ -0.005	-\$46.09
Current Charges			\$1,052.17		Billed Demand	20,000 kW @ 8.660	\$173.20
Total Amount Due			\$1,052.17		Property Tax Recovery Fee		\$23.75
					Gross Receipts Tax		\$26.30
					Total Current Charges		\$1,052.17
Bank Draft Amount							\$1,052.17

NEVER MISS AN ISSUE

Life gets busy. Mail gets misplaced.

The digital edition of the Florida Currents arrives straight to your inbox, every time.

Same trusted stories. Same cooperative news. Just delivered smarter.



Now offering cash bill-pay service at participating retail stores. The barcode below can be scanned at the register, allowing you to make your monthly payment. There is a \$1.50 convenience fee to use this service. To find a location near you, visit pay.vanilladirect.com/pages/retailers



799366433650001102601600960025

By accepting or using this barcode to make a payment, you agree to the full terms and conditions, available at vanilladirect.com/pay/terms. After successful payment using this barcode, you may retrieve your full detailed e-receipt at vanilladirect.com/pay/ereceipt.

The majority of participating locations will accept cash payments up to a maximum amount of \$500.00.

FAMILY DOLLAR

CVS

Walgreens

DOLLAR GENERAL





Peace River Electric Cooperative, Inc.

TREVESTA CDD

Bill Date
Account #
Member #

03/17/2026
160096003
159427

Customer Care 800-282-3824 8am - 5pm M-F
Pay by Phone 855-937-1752
Outage 800-282-3824 24/7
Website www.presco.coop



TOTAL AMOUNT DUE

\$597.07

Bank Draft is scheduled for 04/07/2026

Monthly Energy Use

Kilowatt Hours Previous Months Current Month Avg Temp Temp

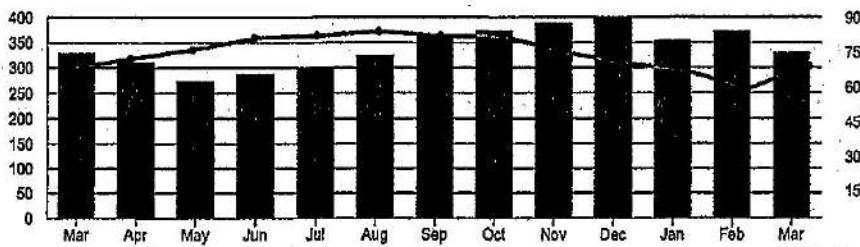

2025

2026

Detailed usage information is available on the SmarHub App or www.presco.coop

Monthly Energy Use Comparison

329 kWh This Month 30 Days

372 kWh Last Month 31 Days

329 kWh This Month Last Year 30 Days

Your Average Daily Use

11 kWh Use

\$18.96 Day Cost not including taxes and fees

Please make check payable to PRECO in U.S. funds and return this portion with your payment.



Peace River Electric Cooperative, Inc.

PO Box 1310
210 Metheny Road
Wauchula, Florida 33873
800.282.3824

Account #
Service Address

160096003
6810 TREVESTA PL

Bank Draft Amount \$597.07
Is scheduled for 04/07/2026



TREVESTA CDD
PO BOX 32414
CHARLOTTE NC 28232-2414

PEACE RIVER ELECTRIC COOPERATIVE, INC.
PO BOX 1547
WAUCHULA FL 33873-1547



Account
160096003

Service Address
6810 TREVISTA PL

Service Description
STREET LIGHTS

Board District
8

Meter #	Service Period		Readings		Meter Multiplier	kWh Usage	kW Reading
	From	To	Previous	Present			
34427038	02/09/2026	03/11/2026	100,872	101,201	1.0	329	0.746
Account Summary				Current Charges			GSD-S
Previous Balance			\$600.59	Facilities Use Charge			\$110.00
Payment(s) Made			-\$600.59	Energy Charge	329 kWh @ 0.083		\$27.31
Balance Forward			\$0.00	CPA	329 kWh @ -0.005		-\$1.65
Current Charges			\$597.07	Billed Demand	50.000 kW @ 8.660		\$433.00
Total Amount Due			\$597.07	Property Tax Recovery Fee			\$13.48
				Gross Receipts Tax			\$14.93
				Total Current Charges			\$597.07
Bank Draft Amount							\$597.07

NEVER MISS AN ISSUE

Life gets busy. Mail gets misplaced.
The digital edition of the Florida Currents arrives straight to your inbox, every time.

Same trusted stories. Same cooperative news. Just delivered smarter.



Sign up for the digital edition of the Florida Currents today.

Now offering cash bill-pay service at participating retail stores. The barcode below can be scanned at the register, allowing you to make your monthly payment. There is a \$1.50 convenience fee to use this service. To find a location near you, visit pay.vanilladirect.com/pages/retailers



799366433650001102601600960033

By accepting or using this barcode to make a payment, you agree to the full terms and conditions, available at vanilladirect.com/pav/terms. After successful payment using this barcode, you may retrieve your full detailed e-receipt at vanilladirect.com/pav/ereceipt.

The majority of participating locations will accept cash payments up to a maximum amount of \$500.00.





Peace River Electric Cooperative, Inc.

TREVESTA CDD

Bill Date
Account #
Member #

03/17/2026
160096004
159427

Customer Care 800-282-3824 8am - 5pm M-F
Pay by Phone 855-937-1752
Outage 800-282-3824 24/7
Website www.preco.coop



TOTAL AMOUNT DUE

\$158.26

Bank Draft is scheduled for 04/07/2026

Monthly Energy Use

Kilowatt Hours Previous Months Current Month Avg Temp Temp

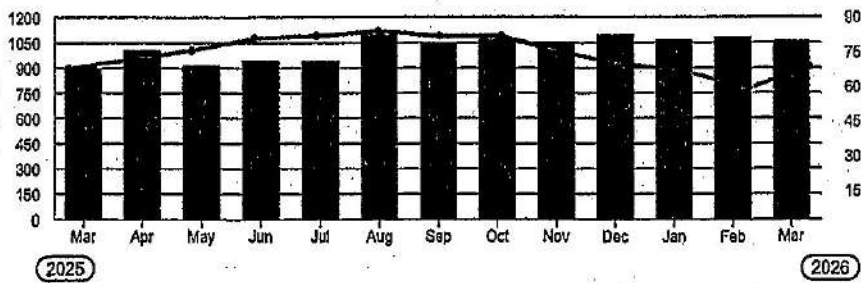

Detailed usage information is available on the SmartHub App or www.preco.coop

Monthly Energy Use Comparison

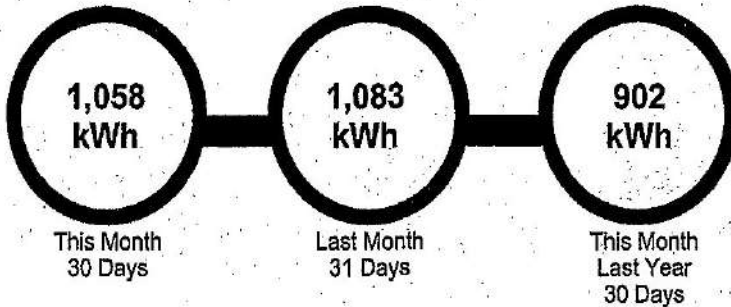

Your Average Daily Use

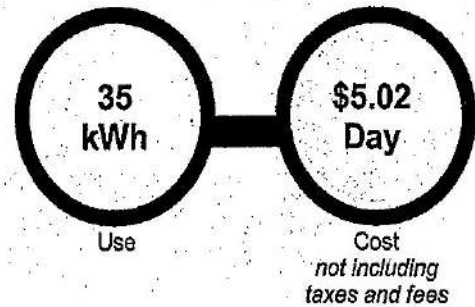

Please make check payable to PRECO in U.S. funds and return this portion with your payment.



Peace River Electric Cooperative, Inc.

PO Box 1310
210 Metheny Road
Wauchula, Florida 33873
800.282.3824

Account # 160096004
Service Address 6581 DEVESTA LOOP

Bank Draft Amount \$158.26
is scheduled for 04/07/2026



TREVESTA CDD
PO BOX 32414
CHARLOTTE NC 28232-2414

PEACE RIVER ELECTRIC COOPERATIVE, INC.
PO BOX 1547
WAUCHULA FL 33873-1547



Account
160096004

Service Address
6581 DEVESTA LOOP

Service Description
FOUNTAIN

Board District
8

Meter #	Service Period		Readings		Meter Multiplier	kWh Usage	kW Reading
	From	To	Previous	Present			
34842876	02/09/2026	03/11/2026	176,526	177,584	1.0	1,058	2.542

Account Summary			Current Charges			GS-S
Previous Balance		\$161.29	Facilities Use Charge			\$28.00
Payment(s) Made		-\$161.29	Energy Charge	1,058 kWh @ 0.121		\$128.02
Balance Forward		\$0.00	CPA	1,058 kWh @ -0.005		-\$5.29
Current Charges		\$158.26	Property Tax Recovery Fee			\$3.57
Total Amount Due		\$158.26	Gross Receipts Tax			\$3.96
			Total Current Charges			\$158.26
Bank Draft Amount						\$158.26

NEVER MISS AN ISSUE

Life gets busy. Mail gets misplaced.

The digital edition of the Florida Currents arrives straight to your inbox, every time.

Same trusted stories. Same cooperative news. Just delivered smarter.

Shop for the digital edition of the Florida Currents Magazine





Now offering cash bill-pay service at participating retail stores. The barcode below can be scanned at the register, allowing you to make your monthly payment. There is a \$1.50 convenience fee to use this service. To find a location near you, visit pay.vanilladirect.com/pages/retailers



799366433650001102601600960041

By accepting or using this barcode to make a payment, you agree to the full terms and conditions, available at vanilladirect.com/pay/terms. After successful payment using this barcode, you may retrieve your full detailed e-receipt at vanilladirect.com/pay/ereceipt.

The majority of participating locations will accept cash payments up to a maximum amount of \$500.00.









Peace River Electric Cooperative, Inc.

TREVESTA CDD

Bill Date
Account #
Member #

03/17/2026
160096005
159427

Customer Care 800-282-3824 8am - 5pm M-F
Pay by Phone 855-937-1752
Outage 800-282-3824 24/7
Website www.precocoop



TOTAL
AMOUNT DUE

\$290.04

Bank Draft is
scheduled for
04/07/2026

Monthly Energy Use

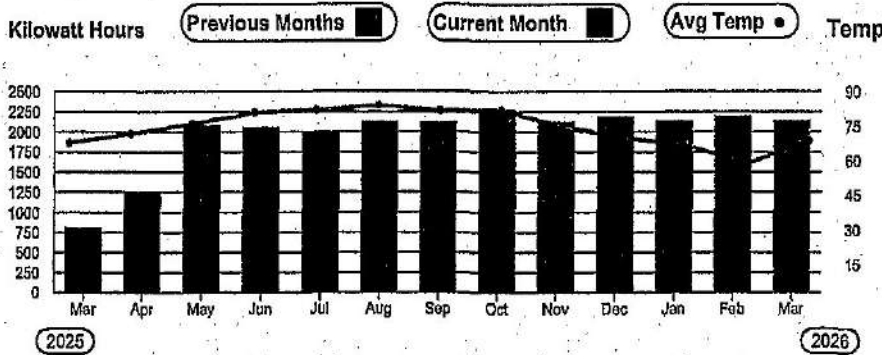

Detailed usage information is available on the SmarHub App or www.precocoop

Monthly Energy Use Comparison

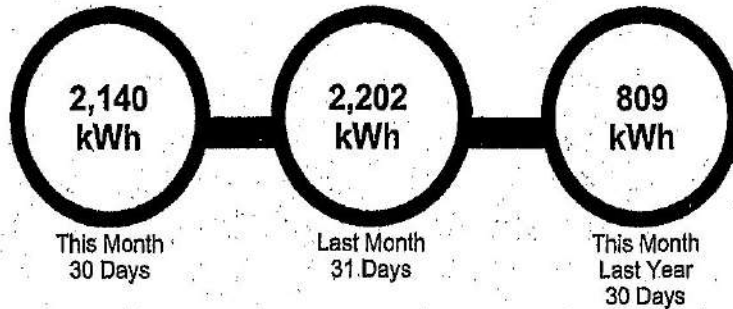

Your Average Daily Use

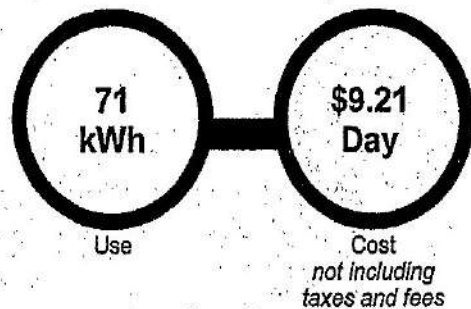

Please make check payable to PRECO in U.S. funds and return this portion with your payment.



Peace River Electric Cooperative, Inc.

PO Box 1310
210 Metheny Road
Wauchula, Florida 33873
800.282.3824

Account # 160096005
Service Address 6727 DEVESTA LOOP

Bank Draft Amount \$290.04
is scheduled for 04/07/2026



TREVESTA CDD
PO BOX 32414
CHARLOTTE NC 28232-2414

PEACE RIVER ELECTRIC COOPERATIVE, INC.
PO BOX 1547
WAUCHULA FL 33873-1547



Account
160096005

Service Address
6727 DEVESTA LOOP

Service Description
FOUNTAIN

Board District
8

Meter #	Service Period		Readings		Meter Multiplier	kWh Usage	kW Reading
	From	To	Previous	Present			
34710733	02/09/2026	03/11/2026	198,636	200,776	1.0	2,140	5.146
Account Summary			Current Charges			GS-S	
Previous Balance			\$297.59	Facilities Use Charge			\$28.00
Payment(s) Made			-\$297.59	Energy Charge	2,140 kWh @ 0.121		\$258.94
Balance Forward			\$0.00	CPA	2,140 kWh @ -0.005		-\$10.70
Current Charges			\$290.04	Property Tax Recovery Fee			\$6.55
Total Amount Due			\$290.04	Gross Receipts Tax			\$7.25
				Total Current Charges			\$290.04
Bank Draft Amount							\$290.04

NEVER MISS AN ISSUE

Life gets busy. Mail gets misplaced.



The digital edition of the Florida Currents arrives straight to your inbox, every time.

Same trusted stories. Same cooperative news. Just delivered smarter.



Sign up for the digital edition of the Florida Currents Magazine.

Now offering cash bill-pay service at participating retail stores. The barcode below can be scanned at the register, allowing you to make your monthly payment. There is a \$1.50 convenience fee to use this service. To find a location near you, visit pay.vanilladirect.com/pages/retailers



799366433650001102601600960058

By accepting or using this barcode to make a payment, you agree to the full terms and conditions, available at vanilladirect.com/pay/terms. After successful payment using this barcode, you may retrieve your full detailed e-receipt at vanilladirect.com/pay/ereceipt.

The majority of participating locations will accept cash payments up to a maximum amount of \$500.00.

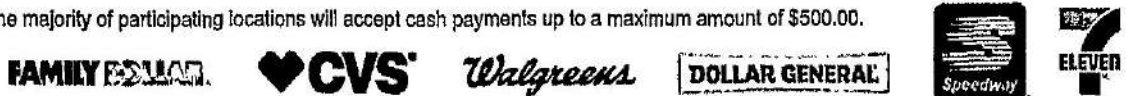



Peace River Electric Cooperative, Inc.

TREVESTA CDD

Bill Date
Account #
Member #

03/17/2026
160096006
159427

Customer Care 800-282-3824 8am - 5pm M-F
Pay by Phone 855-937-1752
Outage 800-282-3824 24/7
Website www.preco.coop



TOTAL AMOUNT DUE
\$39.50
Bank Draft is scheduled for 04/07/2026

Monthly Energy Use

Kilowatt Hours Previous Months Current Month Avg Temp Temp

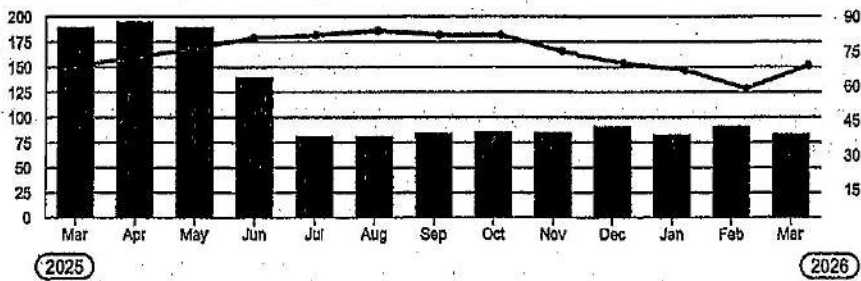

Detailed usage information is available on the SmarHub App or www.preco.coop

Monthly Energy Use Comparison

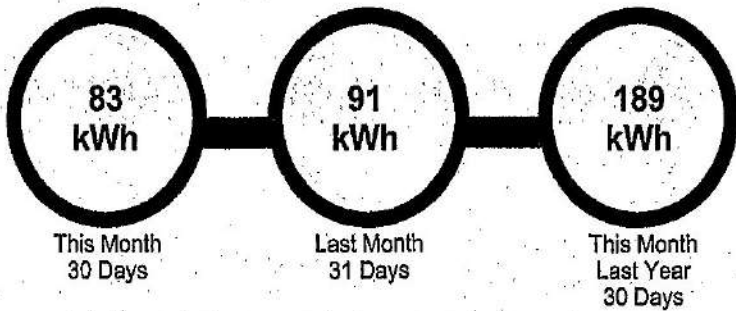

Your Average Daily Use

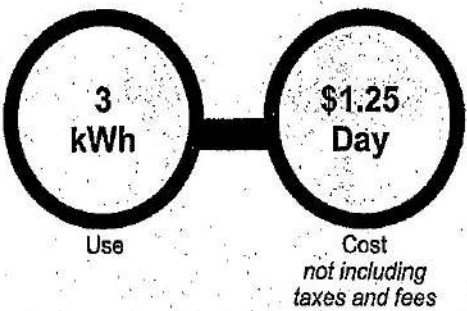

Please make check payable to PRECO in U.S. funds and return this portion with your payment.



Peace River Electric Cooperative, Inc.

PO Box 1310
210 Metheny Road
Wauchula, Florida 33873
800.282.3824

Account # 160096006
Service Address 6405 TREVESTA PL

Bank Draft Amount \$39.50
is scheduled for 04/07/2026



TREVESTA CDD
PO BOX 32414
CHARLOTTE NC 28232-2414

PEACE RIVER ELECTRIC COOPERATIVE, INC.
PO BOX 1547
WAUCHULA FL 33873-1547



Account
160096006

Service Address
6405 TREVISTA PL

Service Description
PUMP

Board District
8

Meter #	Service Period		Readings		Meter Multiplier	kWh Usage	kW Reading
	From	To	Previous	Present			
929096871	02/09/2026	03/11/2026	13,840	13,923	1.0	83	0.126

Account Summary			Current Charges			GS-S
Previous Balance		\$40.47	Facilities Use Charge			\$28.00
Payment(s) Made		-\$40.47	Energy Charge	83 kWh @ 0.121		\$10.04
Balance Forward		\$0.00	CPA	83 kWh @ -0.005		-\$0.42
Current Charges		\$39.50	Property Tax Recovery Fee			\$0.89
Total Amount Due		\$39.50	Gross Receipts Tax			\$0.99
			Total Current Charges			\$39.50
Bank Draft Amount						\$39.50

NEVER MISS AN ISSUE

Life gets busy. Mail gets misplaced.



The digital edition of the Florida Currents arrives straight to your inbox, every time.

Same trusted stories. Same cooperative news. Just delivered smarter.

Sign up for the digital version of the Florida Currents Magazine









Now offering cash bill-pay service at participating retail stores. The barcode below can be scanned at the register, allowing you to make your monthly payment. There is a \$1.50 convenience fee to use this service. To find a location near you, visit pay.vanilladirect.com/pages/retailers

799366433650001102601600960066

By accepting or using this barcode to make a payment, you agree to the full terms and conditions, available at vanilladirect.com/pay/terms. After successful payment using this barcode, you may retrieve your full detailed e-receipt at vanilladirect.com/pay/ereceipt.

The majority of participating locations will accept cash payments up to a maximum amount of \$500.00.



Peace River Electric Cooperative, Inc.

TREVESTA CDD
Bill Date
Account #
Member #

03/17/2026
160096007
159427

Customer Care | 800-282-3824 8am - 5pm M-F
Pay by Phone | 855-937-1752
Outage | 800-282-3824 24/7
Website | www.preco.coop



**TOTAL
AMOUNT DUE**

\$64.72

Bank Draft is
scheduled for
04/07/2026

Monthly Energy Use

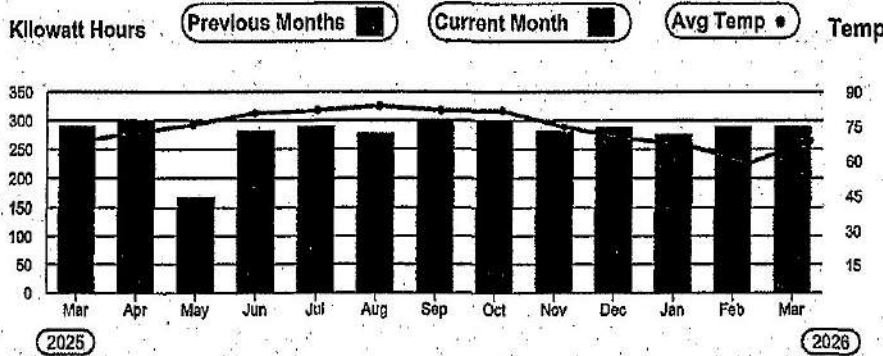

Detailed usage information is available on the SmarHub App or www.preco.coop

Monthly Energy Use Comparison

290
kWh

This Month
30 Days

289
kWh

Last Month
31 Days

291
kWh

This Month
Last Year
30 Days

Your Average Daily Use

10
kWh

Use

\$2.05
Day

Cost
not including
taxes and fees

Please make check payable to PRECO in U.S. funds and return this portion with your payment.



Peace River Electric Cooperative, Inc.

PO Box 1310
210 Metheny Road
Wauchula, Florida 33873
800.282.3824

Account # 160096007
Service Address 6227 KEVESTA AVE

Bank Draft Amount \$64.72
is scheduled for 04/07/2026



TREVESTA CDD
PO BOX 32414
CHARLOTTE NC 28232-2414

PEACE RIVER ELECTRIC COOPERATIVE, INC.
PO BOX 1547
WAUCHULA FL 33873-1547



Account
160096007

Service Address
6227 KEVESTA AVE

Service Description
PUMP

Board District
8

Meter #	Service Period		Readings		Meter Multiplier	kWh Usage	kW Reading
	From	To	Previous	Present			
36675115	02/09/2026	03/11/2026	23,844	24,134	1.0	290	0.41
Account Summary			Current Charges			GS-S	
Previous Balance			\$64.59	Facilities Use Charge			\$28.00
Payment(s) Made			-\$64.59	Energy Charge	290 kWh @ 0.121		\$35.09
Balance Forward			\$0.00	CPA	290 kWh @ -0.005		-\$1.45
Current Charges			\$64.72	Property Tax Recovery Fee			\$1.46
Total Amount Due			\$64.72	Gross Receipts Tax			\$1.62
				Total Current Charges			\$64.72
Bank Draft Amount							\$64.72

NEVER MISS AN ISSUE

Life gets busy. Mail gets misplaced.
The digital edition of the Florida Currents arrives straight to your inbox, every time.

Same trusted stories. Same cooperative news. Just delivered smarter.



Now offering cash bill-pay service at participating retail stores. The barcode below can be scanned at the register, allowing you to make your monthly payment. There is a \$1.50 convenience fee to use this service. To find a location near you, visit pay.vanilladirect.com/pages/retailers



799366433650001102601600960074

By accepting or using this barcode to make a payment, you agree to the full terms and conditions, available at vanilladirect.com/pay/terms. After successful payment using this barcode, you may retrieve your full detailed e-receipt at vanilladirect.com/pay/receipt.

The majority of participating locations will accept cash payments up to a maximum amount of \$500.00.









Peace River Electric Cooperative, Inc.

TREVESTA CDD
Bill Date
Account #
Member #

03/17/2026
160096008
159427

Customer Care | 800-282-3824 8am - 5pm M-F
Pay by Phone | 855-937-1752
Outage | 800-282-3824 24/7
Website | www.precocoop



TOTAL AMOUNT DUE

\$65.20

Bank Draft Is scheduled for 04/07/2026

Monthly Energy Use

Kilowatt Hours Previous Months Current Month Avg Temp Temp

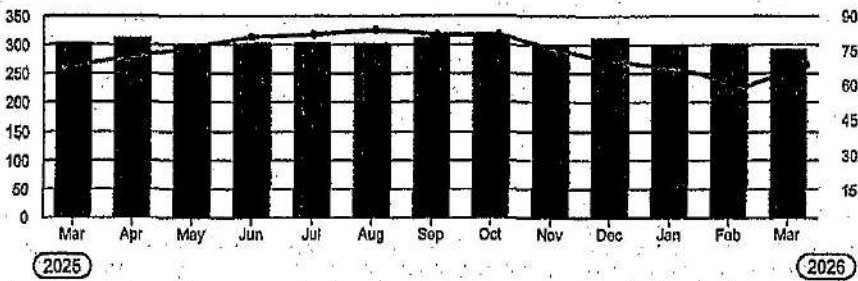

Detailed usage information is available on the SmartHub App or www.precocoop

Monthly Energy Use Comparison

294 kWh

This Month
30 Days

303 kWh

Last Month
31 Days

304 kWh

This Month
Last Year
30 Days

Your Average Daily Use

10 kWh

Use

\$2.07 Day

Cost
not including
taxes and fees

Please make check payable to PRECO in U.S. funds and return this portion with your payment.



Peace River Electric Cooperative, Inc.

PO Box 1310
210 Metheny Road
Wauchula, Florida 33873
800.282.3824

Account #
Service Address

160096008
6234 KEVESTA AVE

Bank Draft Amount **\$65.20**
is scheduled for 04/07/2026



TREVESTA CDD
PO BOX 32414
CHARLOTTE NC 28232-2414

PEACE RIVER ELECTRIC COOPERATIVE, INC.
PO BOX 1547
WAUCHULA FL 33873-1547



Account
160096008

Service Address
6234 KEVESTA AVE

Service Description
AERATOR

Board District
8

Meter #	Service Period		Readings		Meter Multiplier	kWh Usage	kW Reading
	From	To	Previous	Present			
38695968	02/09/2026	03/11/2026	10,520	10,814	1.0	294	0.42
Account Summary			Current Charges			GS-S	
Previous Balance			\$66.30	Facilities Use Charge			\$28.00
Payment(s) Made			-\$66.30	Energy Charge	294 kWh @ 0.121		\$35.57
Balance Forward			\$0.00	CPA	294 kWh @ -0.005		-\$1.47
Current Charges			\$65.20	Property Tax Recovery Fee			\$1.47
Total Amount Due			\$65.20	Gross Receipts Tax			\$1.63
				Total Current Charges			\$65.20
Bank Draft Amount							\$65.20

NEVER MISS AN ISSUE

Life gets busy. Mail gets misplaced.



The digital edition of the Florida Currents arrives straight to your inbox, every time.

Same trusted stories. Same cooperative news. Just delivered smarter.

Sign up for the digital edition of Florida Currents Magazine









Now offering cash bill-pay service at participating retail stores. The barcode below can be scanned at the register, allowing you to make your monthly payment. There is a \$1.50 convenience fee to use this service. To find a location near you, visit pay.vanilladirect.com/pages/retailers

799366433650001102601600960082

By accepting or using this barcode to make a payment, you agree to the full terms and conditions, available at vanilladirect.com/pav/terms. After successful payment using this barcode, you may retrieve your full detailed e-receipt at vanilladirect.com/pav/ereceipt.

The majority of participating locations will accept cash payments up to a maximum amount of \$500.00.

Rizzetta & Company, Inc.
 3434 Colwell Avenue
 Suite 200
 Tampa FL 33614

Invoice

Date	Invoice #
4/2/2026	INV0000108036

Bill To:

TREVESTA CDD 3434 Colwell Avenue Suite 200 Tampa FL 33614
--

Services for the month of	Terms	Client Number
April	Upon Receipt	00241

Description	Qty	Rate	Amount
Accounting Services	1.00	\$1,772.58	\$1,772.58
Administrative Services	1.00	\$443.17	\$443.17
Dissemination Services	1.00	\$583.33	\$583.33
Email Accounts, Admin & Maintenance	5.00	\$20.00	\$100.00
Financial & Revenue Collections	1.00	\$354.50	\$354.50
Landscape Consulting Services	1.00	\$1,000.00	\$1,000.00
Management Services	1.00	\$2,107.33	\$2,107.33
Website Compliance & Management	1.00	\$100.00	\$100.00
Subtotal			\$6,460.91
Total			\$6,460.91

INVOICE

Sitex Aquatics, LLC
PO Box 917
Parrish, FL 34219

office@sitexaquatics.com
+1 (813) 564-2322



Bill to

Trevesta CDD
Rizzetta
3434 Colwell Ave, Suite 200
Tampa, FL 33614
Taylor Nielsen

Invoice details

Invoice no.: 10870-b
Terms: Net 30
Invoice date: 03/17/2026
Due date: 04/16/2026

#	Date	Product or service	Description	Qty	Rate	Amount
1.		Fountain Repairs	Adjust timers	1	\$185.00	\$185.00
					Total	\$185.00

INVOICE

Sitex Aquatics, LLC
PO Box 917
Parrish, FL 34219

office@sitexaquatics.com
+1 (813) 564-2322



Bill to

Trevesta CDD
Rizzetta & Company
3434 Colwell Ave
Suite 200
Tampa, FL 33614

Invoice details

Invoice no.: 10911-b
Terms: Net 30
Invoice date: 04/01/2026
Due date: 05/01/2026

#	Date	Product or service	Description	Qty	Rate	Amount
1.		Fountain Maintenance	Quarterly Fountain Cleaning	1	\$1,000.00	\$1,000.00

Total **\$1,000.00**

Ways to pay

BANK

[View and pay](#)

INVOICE

Sitex Aquatics, LLC
PO Box 917
Parrish, FL 34219

office@sitexaquatics.com
+1 (813) 564-2322



Bill to

Trevesta CDD
Rizzetta
P.O. Box 32414 Charlotte, NC 28232

Invoice details

Invoice no.: 10963-b
Terms: Net 30
Invoice date: 04/01/2026
Due date: 05/01/2026

#	Date	Product or service	Description	Qty	Rate	Amount
1.		Aquatic Maintenance	Monthly Lake Maintenance-19 Waterways	1	\$2,255.00	\$2,255.00

Total **\$2,255.00**

Ways to pay

BANK

[View and pay](#)



INVOICE

Invoice Number	2542860
Invoice Date	March 12, 2026
Customer Number	182403
Project Number	238202181

Bill To

Trevesta Community
Development District
PO Box 32414
Charlotte NC 28232
United States

Alternative Remit To

Stantec Consulting Services Inc.
(SCSI)
13980 Collections Center Drive
Chicago IL 60693
United States
Federal Tax ID
11-2167170

Project Description: Trevesta Community Development District.

Stantec Project Manager:	Nolte, Frank
Current Invoice Due:	\$1,404.00
For Period Ending:	March 6, 2026

Net Due in 30 Days or in accordance with terms of the contract

Stantec will not change our banking information. If you receive a request noting our banking information has changed, please contact your Stantec Project Manager

INVOICE

Invoice Number

2542860

Project Number

238202181

Top Task 2026 2026 FY General Cons

Professional Services

Category/Employee	Hours	Rate	Current Amount
Nolte, Robert (Frank)	9.00	156.00	1,404.00
	9.00		1,404.00
Professional Services Subtotal	9.00		1,404.00

Top Task 2026 Total **1,404.00**

Total Fees & Disbursements \$1,404.00

INVOICE TOTAL (USD) **\$1,404.00**

Billing Backup - Roster

Date	Project	Task	Expnd Type	Employee/Supplier	Quantity	Bill Rate	Bill Amount	Comment
2026-01-05	238202181	2026	Direct - Regular	NOLTE, ROBERT (FRANK)	1.00	156.00	156.00	REVIEWING SWFWMD WEBSITE FOR ANY OUTSTANDING O&M PERMITS.
2026-02-11	238202181	2026	Direct - Regular	NOLTE, ROBERT (FRANK)	3.00	156.00	468.00	PREPARING FOR AND ATTENDING CDD MEETING.
2026-02-20	238202181	2026	Direct - Regular	NOLTE, ROBERT (FRANK)	1.00	156.00	156.00	REVIEWING REGULATIONS FOR CELL TOWER INSTALLATION WITHIN MANATEE COUNTY. PUBLIC RECORDS REQUEST FROM MANATEE COUNTY FOR APPLICABLE PLANS ASSOCIATED WITH TRACT F-3.
2026-02-24	238202181	2026	Direct - Regular	NOLTE, ROBERT (FRANK)	1.00	156.00	156.00	REQUESTING DESIGN PLANS AND CONSERVATION EASEMENTS FROM MANATEE COUNTY FOR TRACT F3 REVIEW
2026-02-25	238202181	2026	Direct - Regular	NOLTE, ROBERT (FRANK)	3.00	156.00	468.00	REVIEWING CELL TOWER INSTALLATION REQUIREMENTS. DRAFTING MEMO TO BOARD. UPDATING MAINTENANCE MAP TO REFLECT F3 OWNERSHIP/MAINTENANCE TRANSFER TO CDD
Total Labor:					9.00		\$1,404.00	
Total Project 238202181					9.00		\$1,404.00	



INVOICE

Invoice Number	2548489
Invoice Date	April 6, 2026
Customer Number	182403
Project Number	238202181

Bill To

Trevesta Community
Development District
PO BOX 32414
Charlotte, NC 28232
United States

Alternative Remit To

Stantec Consulting Services Inc.
(SCSI)
13980 Collections Center Drive
Chicago IL 60693
United States
Federal Tax ID
11-2167170

Project Description: Trevesta Community Development District_

Stantec Project Manager:	Nolte, Frank
Current Invoice Due:	\$1,872.00
For Period Ending:	April 3, 2026

Net Due in 30 Days or in accordance with terms of the contract

Stantec will not change our banking information. If you receive a request noting our banking information has changed, please contact your Stantec Project Manager

INVOICE

Invoice Number

2548489

Project Number

238202181

Top Task 2026

2026 FY General Cons

Professional Services

Category/Employee

Hours

Rate

**Current
Amount**

Nolte, Robert (Frank)

12.00

156.00

1,872.00

12.00

1,872.00

Professional Services Subtotal

12.00

1,872.00

Top Task 2026 Total

1,872.00

Total Fees & Disbursements

\$1,872.00

INVOICE TOTAL (USD)

\$1,872.00

Date	Project	Task	Expnd Type	Employee/Supplier	Quantity	Bill Rate	Bill Amount	Comment
2026-03-25	238202181	2026	Direct - Regular	NOLTE, ROBERT (FRANK)	4.00	156.00	624.00	PREPARING FOR AND ATTENDING SITE VISIT TO REVIEW REPORTED EROSION ALONG THE SOUTHERN SECTION OF POND 10. UPLOADING PHOTOS.
2026-03-27	238202181	2026	Direct - Regular	NOLTE, ROBERT (FRANK)	2.00	156.00	312.00	REVIEWING POND 10 PLANS FOR ORIGINAL CONDITION OF POND BANK VS CURRENT CONDITION.
2026-04-01	238202181	2026	Direct - Regular	NOLTE, ROBERT (FRANK)	3.00	156.00	468.00	REVIEWING POND 10 GRADING PLAN, PHOTOS OF EXISTING POND BANK, PREPARING PROPOSED CROSS SECTION AND EXPECTED COST FOR REPAIRS
2026-04-02	238202181	2026	Direct - Regular	NOLTE, ROBERT (FRANK)	3.00	156.00	468.00	REVIEWING POND 10 GRADING PLAN, PHOTOS OF EXISTING POND BANK, PREPARING PROPOSED CROSS SECTION AND EXPECTED COST FOR REPAIRS
Total Labor:					12.00		\$1,872.00	
Total Project 238202181					12.00		\$1,872.00	

Tab 16

MINUTES OF MEETING

Each person who decides to appeal any decision made by the Board with respect to any matter considered at the meeting is advised that the person may need to ensure that a verbatim record of the proceedings is made, including the testimony and evidence upon which such appeal is to be based.

**TREVESTA
COMMUNITY DEVELOPMENT DISTRICT**

The regular meeting of the Board of Supervisors of Trevesta Community Development District was held on **Wednesday, April 8, 2026, at 3:00 p.m.** at the Trevesta Clubhouse, located at 6120 Trevesta Place, Palmetto, FL 34221.

Present and constituting a quorum were:

Dave Hoyt	Board Supervisor, Chairman
William Dornetto	Board Supervisor, Vice Charman
Joseph Powlis	Board Supervisor, Assistant Secretary

Also present were:

Sam Stevens	District Manager, Rizzetta & Company, Inc.
Matt O’Nolan	District Manager, Rizzetta & Company, Inc.
Haley Pryor	Landscape Inspection Specialist, Rizzetta & Company, Inc.
Patrick Collins	District Counsel, Kilinski Van Wyk
Frank Nolte	Representative, Stantec
Steve Sutton	Representative, Bloomings Landscaping

Audience	None
----------	-------------

FIRST ORDER OF BUSINESS **Call to Order**

Ms. Stevens called the meeting to order and conducted the roll call.

SECOND ORDER OF BUSINESS **Public Comment**

No audience members were present.

THIRD ORDER OF BUSINESS **Staff Reports**

A. Presentation of Landscape Report and Responses

Ms. Pryor presented her report to the Board.

The Board inquired about a leaning tree affecting a neighboring HOA. Mr. O’Nolan stated that based on his site visit, the tree does not appear hazardous, but he will schedule an arborist to provide an official report to guide the board's decision. Mr. Sutter, who looked at the tree that morning, confirmed it is about fifteen feet inside the preserve and also does not look hazardous, but he will get the arborist's official opinion. He

46 suggested that subordinating the tree (trimming the canopy by a third) could be an option
47 to reduce weight.

48 **B. Aquatics Report**

49 The Board reviewed the monthly Aquatics Report.

50

51 **i. Consideration of Aquatic Proposals**

52

On a Motion by Mr. Piwowar, seconded by Mr. Lafollette, with all in favor, the Board approved District Manager to work with Sitex to locate ponds that need midge fly treatment at a not-to-exceed amount of \$15,000.00, for the Trevesta Community Development District.

53

54 The Fountain Aerator proposal was tabled and the Board asked Sitex to
55 present a new proposal with electrical installation for the fountain aerator.

56

57 **C. District Counsel**

58 Mr. Collins stated seats up for election in November 2026 must qualify with
59 Manatee County Supervisor of Elections between Noon, June 8, 2026
60 through Noon June 12, 2026 and recommends qualifying in-person.

61

62 **D. District Engineer**

63 Mr. Nolte presented his report to the Board.

64

On a Motion by Mr. Powlis, seconded by Mr. Dornetto, with all in favor, the Board approved not to mow the wetland behind Gavella Cove, for the Trevesta Community Development District.

65

66 **E. District Manager**

67 Ms. Stevens advised that the next meeting of the Board of Supervisors is
68 scheduled for Wednesday, June 3, 2026, at 3:00 p.m. at the Trevesta
69 Clubhouse.

70

71 **1. Review of District Manager Report**

72 Ms. Stevens presented the District Manager Report to the Board.

73

On a Motion by Mr. Powlis, seconded by Mr. Dornetto, with all in favor, the Board approved to move Access Operating Fund account to Valley Bank, for the Trevesta Community Development District.

74

75

76

77

78

79 **FOURTH ORDER OF BUSINESS**

**Review of Financial Statements for
January & February 2026**

80
81
82

On a Motion by Mr. Lafollette, seconded by Mr. Piwowar, with all in favor, the Board approved the January & February 2026 Financial Statements, for the Trevesta Community Development District.

83
84 **FIFTH ORDER OF BUSINESS**

**Consideration of Operations and
Maintenance Expenditures for
January & February 2026**

85
86
87

On a Motion by Mr. Hoyt, seconded by Mr. Dornetto, with all in favor, the Board approved the Operation and Maintenance Expenditures for January 2026 (\$48,406.57) and February 2026 (\$25494.57), for the Trevesta Community Development District.

88
89 **SIXTH ORDER OF BUSINESS**

**Consideration of Minutes of the
Regular meeting held on February 11,
2026**

90
91
92

On a Motion by Mr. Hoyt, seconded by Mr. Dornetto, with all in favor, the Board approved the minutes of the regular meeting held on February 11, 2026, for the Trevesta Community Development District.

93
94 **SEVENTH ORDER OF BUSINESS**

**Consideration of Resolution 2026-02;
General Election**

95
96

On a Motion by Mr. Piwowar, seconded by Mr. Dornetto, with all in favor, the Board approved Resolution 2026-02; General Election, for the Trevesta Community Development District.

97
98 **EIGHTH ORDER OF BUSINESS**

**Ratification of Audit Engagement
Letter**

99
100

On a Motion by Mr. Hoyt, seconded by Mr. Dornetto, with all in favor, the Board ratified the audit engagement letter for McDirmit Davis for Fiscal Year September 30, 2025, for the Trevesta Community Development District.

101
102
103
104

105
106
107
108
109
110
111
112
113
114
115
116
117
118
119
120
121
122
123
124
125
126
127
128

129
130
131
132
133
134
135

NINTH ORDER OF BUSINESS

Discussion of Lake Trevesta Bank Erosion

The Board directed phased, itemized proposals and prioritization by severity for minor to moderate erosion, with rough cost ~\$120,000 and potential phased funding next the fiscal year.

TENTH ORDER OF BUSINESS

Discussion of Wild Pigs

There have been resident emails reporting activity and turf damage near homes. The Board directed staff to ensure trapper documentation and photos are received.

ELEVENTH ORDER OF BUSINESS

Supervisor Requests

Supervisor Dornetto directed Staff to check with Manatee County regarding painting and re-striping Trevesta Boulevard and to get proposals for 3 signs for entrances.

TWELFTH ORDER OF BUSINESS

Adjournment

Ms. Stevens stated there was no further business to come before the Board and asked for a motion to adjourn the meeting.

On a Motion by Mr. Piwovar, seconded by Mr. Dornetto, with all in favor, the Board adjourned the meeting at 5:23 p.m., for the Trevesta Community Development District.

Secretary / Assistant Secretary

Chairman / Vice Chairman